

**3-SPEED STEREO TURNTABLE WITH METAL TONE  
ARM AND BLUETOOTH TRANSMIT**





**JTA-455  
USER MANUAL**



**PLEASE READ THIS USER MANUAL COMPLETELY BEFORE OPERATING THIS  
UNIT AND RETAIN THIS BOOKLET FOR FUTURE REFERENCE**

## WARNING

TO PREVENT FIRE OR SHOCK HAZARD, DO NOT USE THIS PLUG WITH AN EXTENSION CORD, RECEPTACLE OR OTHER OUTLET UNLESS THE BLADES CAN BE FULLY INSERTED TO PREVENT BLADE EXPOSURE. TO PREVENT FIRE OR SHOCK HAZARD, DO NOT EXPOSE THIS APPLIANCE TO RAIN OR MOISTURE.

|   |  |   |
|---|--|---|
|  <p>The lightning flash and arrow head within the triangle is a warning sign alerting you of "dangerous voltage" inside the product.</p> | <p style="text-align: center;"><b>CAUTION</b><br/><b>RISK OF ELECTRIC SHOCK</b><br/><b>DO NOT OPEN</b></p> <p>CAUTION: TO REDUCE THE RISK OF ELECTRIC SHOCK DO NOT REMOVE COVER (ON BACK), NO USER SERVICEABLE PARTS INSIDE. REFER SERVICING TO QUALIFIED SERVICE PERSONNEL.</p> |  <p>The exclamation point within the triangle is a warning sign alerting you of important instructions accompanying the product.</p> |
|---|--|---|

The Caution Marking and Rating label are located at the bottom enclosure of the apparatus.

## IMPORTANT SAFETY INSTRUCTIONS

1. Read these instructions.
2. Keep these instructions.
3. Heed all warnings.
4. Follow all instructions.
5. Do not use this apparatus near water.
6. Clean only with dry cloth.
7. Do not block any ventilation openings. Install in accordance with the manufacturer's instructions.
8. Do not install near any heat sources such as radiators, heat registers, stoves, or other apparatus (including amplifiers) that product heat.
9. Do not defeat the safety purpose of the polarized or grounding-type plug. A polarized plug has two blades with one wider than the other. A grounding type plug has two blades and a third grounding prong. The wide blade or the third prong is provided for your safety. If the provided plug does not fit into your outlet, consult an electrician for replacement of the obsolete outlet.
10. Protect the power cord from being walked on or pinched particularly at plugs, convenience receptacles, and the point where they exit from the apparatus.
11. Only use attachments/accessories specified by the manufacturer.
12. Use only with a cart, stand, tripod, bracket, or table recommended by the manufacturer, or sold with the product. When a cart is used, use caution when moving the cart/apparatus combination to avoid injury from tip-over.
13. Unplug this apparatus during lightning storms or when unused for a long periods of time.
14. Refer all servicing to qualified service personnel. Servicing is required when the apparatus has been damaged in any way, such as power-supply cord or plug is damaged, liquid has been spilled or objects have fallen into the apparatus, the apparatus has been exposed to rain or moisture, does not operate normally, or has been dropped.
15. This appliance shall not be exposed to dripping or splashing water and that no object filled with liquids such as vases shall be placed on the apparatus.
16. Do not overload wall outlet. Use only power source as indicated.



17. Use replacement part as specified by the manufacturer.
18. Upon completion of any service or repairs to this product, ask the service technician to perform safety checks.
19. Power Sources - This product should be operated only from the type of power source indicated on the marking label. If you are not sure of the type of power supply to your home, consult your product dealer or local power company. For products intended to operate from battery power, or other sources, refer to the operating instruction.
20. Object and Liquid Entry - Never push objects of any kind into this product through openings as they may touch dangerous voltage points or short-out parts that could result in a fire or electric shock. Never spill liquid of any kind on the product.
21. Damage Requiring Service - Unplug this product from the wall outlet and refer servicing to qualified service personnel under the following conditions:
  - a) When the power-supply cord or plug is damaged,
  - b) If liquid has been spilled, or objects have fallen into the product,
  - c) If the product has been exposed to rain or water,
  - d) If the product does not operate normally by following the operating instructions. Adjust only those controls that are covered by the operating instructions as an improper adjustment of other controls may result in damage and will often require extensive work by a qualified technician to restore the product to its normal operation.
  - e) If the product has been dropped or damaged in any way, and
  - f) When the product exhibits a distinct change in performance - this indicates a need for service.
22. Main plug is used as disconnect device and it should remain readily operable during intended use. In order to disconnect the apparatus from the mains completely, the mains plug should be disconnected from the mains socket outlet completely.
23. Battery shall not be exposed to excessive heat such as sunshine, fire or the like.
24. Excessive sound pressure from earphones and headphone can cause hearing loss.

This symbol indicates that this product incorporates double insulation between hazardous mains voltage and user accessible parts.

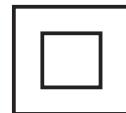

**CAUTION:**  
TO PREVENT ELECTRIC SHOCK, MATCH WIDE  
BLADE OF AC PLUG TO WIDE SLOT. FULLY INSERT.

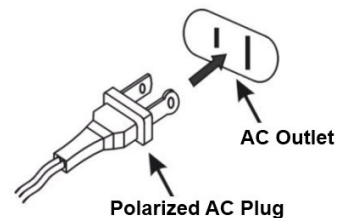

# SAVE THESE INSTRUCTIONS

## COMPLIANCE WITH FCC REGULATIONS

FCC ID RQU-TT-933BPG

This device complies with Part 15 of the FCC Rules. Operation is subject to the following two conditions:

- (1) this device may not cause harmful interference, and
- (2) this device must accept any interference received, including interference that may cause undesired operation.

**NOTE :** This equipment has been tested and found to comply with the limits for a Class B digital device, pursuant to Part 15 of the FCC Rules. These limits are designed to provide reasonable protection against harmful interference in a residential installation. This equipment generates, uses and can radiate radio frequency energy and, if not installed and used in accordance with the instructions, may cause harmful interference to radio communications. However, there is no guarantee that interference will not occur in a particular installation. If this equipment does cause harmful interference to radio or television reception, which can be determined by turning the equipment off and on, the user is encouraged to try to correct the interference by one or more of the following measures:

- Reorient or relocate the receiving antenna.
- Increase the separation between the equipment and receiver.
- Connect the equipment into an outlet on a circuit different from that to which the receiver is connected.
- Consult the dealer or an experienced radio/TV technician for help.

**CAUTION: Changes or modifications not expressly approved by the party responsible for compliance could void the user's authority to operate the equipment.**

## PROTECT YOUR FURNITURE

This system is equipped with non-skid rubber 'feet' to prevent the product from moving when you operate the controls. These 'feet' are made from non-migrating rubber material specially formulated to avoid leaving any marks or stains on your furniture. However certain types of oil based furniture polishes, wood preservatives, or cleaning sprays may cause the rubber 'feet' to soften, and leave marks or a rubber residue on the furniture.

To prevent any damage to your furniture we strongly recommend that you purchase small self-adhesive felt pads, available at hardware stores and home improvement centers everywhere, and apply these pads to the bottom of the rubber 'feet' before you place the product on fine wooden furniture.

## DEAR JENSEN® CUSTOMER

Selecting fine audio equipment such as the unit you've just purchased is only the start of your musical enjoyment. Now it's time to consider how you can maximize the fun and excitement your equipment offers. This manufacturer and the Electronic Industries Association's Consumer Electronics Group want you to get the most out of your equipment by playing it at a safe level. One that lets the sound come through loud and clear without annoying blaring or distortion and, most importantly, without affecting your sensitive hearing.

Sound can be deceiving. Over time your hearing "comfort level" adapts to higher volumes of sound. So what sounds "normal" can actually be loud and harmful to your hearing. Guard against this by setting your equipment at a safe level BEFORE your hearing adapts.

### To establish a safe level:

- Start your volume control at a low setting.
- Slowly increase the sound until you can hear it comfortably and clearly, and without distortion.
- Once you have established a comfortable sound level: Set the dial and leave it there.

Taking a minute to do this now will help to prevent hearing damage or loss in the future. After all, we want you listening for a lifetime.

### We Want You Listening For a Lifetime

Used wisely, your new sound equipment will provide a lifetime of fun and enjoyment. Since hearing damage from loud noise is often undetectable until it is too late, this manufacturer and the Electronic Industries Association's Consumer Electronics Group recommend you avoid prolonged exposure to excessive noise.



### Customer's Record:

The serial number of this product is found on its back cover. You should note the serial number of this unit in the space provided as a permanent record of your purchase to aid in identification in the event of theft or loss.

**Model Number: JTA-455**

**Serial Number: \_\_\_\_\_**

## ACCESSORIES INCLUDED

- Application CD
- USB cable
- 45 RPM Record Adapter
- User Manual

## LOCATION OF CONTROLS

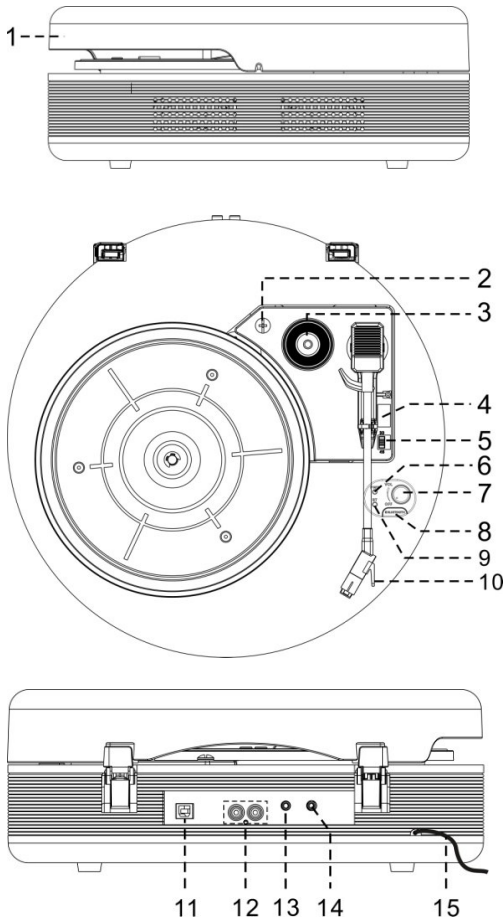

- 1 DUST COVER
- 2 ANTI-SHOCK LOCK DOWN SCREW
- 3 45 RPM ADAPTER
- 4 AUTO STOP SWITCH
- 5 33/45/78 RPM SPEED SELECTOR
- 6 POWER INDICATOR
- 7 POWER ON/OFF AND VOLUME CONTROL KNOB
- 8 BLUETOOTH BUTTON
- 9 BLUETOOTH LED INDICATOR
- 10 TONE ARM LIFT
- 11 USB PORT FOR COMPUTER CONNECTION
- 12 RCA LINE-OUT JACKS
- 13 AUX-IN JACK
- 14 HEADPHONE JACK
- 15 AC POWER CORD

### Caution:

Usage of controls or adjustments or performance of procedures other than those specified herein may result in hazardous radiation exposure.

This unit should not be adjusted or repaired by anyone except qualified service personnel.

## AC OPERATION

1. Connect the AC POWER CORD (#15) to an AC outlet.
2. Rotate the POWER ON/OFF AND VOLUME CONTROL KNOB (#7) clockwise to turn on the system. The POWER INDICATOR (#6) will light up.

## ANTI-SHOCK LOCK DOWN SCREW

**IMPORTANT:** This turntable features a built in Anti-Shock system, and the turntable is locked down when shipped from the factory. Rotate the ANTI-SHOCK LOCK DOWN SCREW (#2), in a clockwise direction to release the turntable and activate the anti-shock feature before using the turntable.

## STEREO PHONOGRAPH OPERATION

### Please Note - Before Use

- Remove the stylus protector.
- Make sure the BLUETOOTH BUTTON (#8) is in the up (OFF) position
- Make sure that the tone arm is unlocked and free to move from the tone arm rest prior to operating. Lock the tone arm again when not in use.

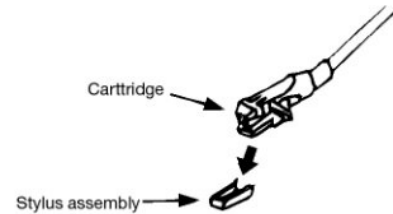

1. Raise the JTA-455 DUST COVER (#1).
2. Rotate the POWER ON/OFF AND VOLUME CONTROL KNOB (#7) clockwise to turn on the JTA-455
3. Place the record on the platter [use the 45 RPM ADAPTER (#3) if you are playing 45 RPM records].
4. Set the 33/45/78 RPM SPEED SELECTOR (#5) to the proper position for the record you are playing.
5. Lift the tone arm from the rest and slowly move it over the record.. The turntable platter will begin turning.
6. Place the tone arm down onto the record at the location that you want to play.
7. Adjust the POWER ON/OFF AND VOLUME CONTROL KNOB (#7) to the desired level.
8. At the end of record, the platter will automatically stop rotating. Lift the tone arm from the record and return it to the rest.
9. To stop playing manually, lift the Tone Arm up from the record and return it to the arm rest.

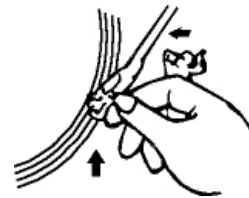

**Remark :** Certain records may have an auto-stop area outside the unit setting, so it will stop before the last track finishes. When this happens, set the auto-stop switch (#13) to the " off " position. This will disable the auto-stop feature, and the record will run to the end of the record but will not automatically stop. Place the tone arm back in the rest position.

## BLUETOOTH CONNECTION

### Pairing the turntable with a new Bluetooth speaker system:

1. Turn on your Bluetooth speaker system and place it in pairing/search mode.
2. Rotate the POWER/VOLUME ON/OFF SWITCH (#7) clockwise to turn on the JTA-455. The Bluetooth LED indicator (#9) will start slowly flashing (1 time/second), indicating the Bluetooth transmitter is now in searching/connecting mode. The JTA-455 will remain in this searching mode for around 30 seconds. If the JTA-455 Bluetooth transmitter cannot find any previously paired Bluetooth speakers, it will enter pairing mode and the Bluetooth LED indicator (#9) will begin flashing at a faster rate (2 times/second). The new Bluetooth speaker system will be paired automatically. If pairing is unsuccessful, the JTA-455 will return to standby mode automatically and the Bluetooth LED indicator (#9) will begin flashing slowly (1 time every 5 seconds).

3. Once connected to the Bluetooth speaker system, the Bluetooth LED indicator (#9) of the JTA-455 will light steadily and the JTA-455 internal speakers will switch off automatically.
4. You can now start wirelessly streaming your records from the JTA-455 to your Bluetooth speaker system.
5. If you want to pair or connect the JTA-455 to another Bluetooth speaker system, press Bluetooth button (#8) once, and the JTA-455 Bluetooth transmitter will return to standby mode.
6. Turn on another Bluetooth speaker system you want to connect, and set it to pairing/search mode if it is a new device. Press the Bluetooth button (#8) again and the JTA-455 Bluetooth transmitter will search/pair with the new Bluetooth speaker system.

**Playing music from your records to a Bluetooth speaker wirelessly:**

1. Select your favorite song, see above "STEREO PHONOGRAPH OPERATION".
2. Slowly adjust the volume controls of your Bluetooth device until you reach a comfortable listening level.

**Notes:**

1. Refer to the operation manual of Bluetooth speaker since it may vary from model to model.
2. Remember to turn off the JTA-455 when you have finished listening,
3. Don't forget to switch off the power of your Bluetooth speaker as well.

## AUX-IN OPERATION

You can play other music sources (iPod, MP3 or other digital audio players) through the speakers of the JTA-455 by connecting the AUX IN JACK (#13) to your external player's audio out jack or headphone jack.

1. Use an audio cable (not included) with one 3.5 mm stereo plug on each end of the cable.
2. Plug one end into the AUX IN JACK (#13) on the JTA-455 and the other end of the cable into the Line-out Jack or Headphone Jack of your external audio device. It will automatically switch the unit to AUX mode.
3. Turn on the JTA-455.
4. Start playing the device you plugged into the AUX IN JACK (#13).
5. Slowly adjust both the volume controls of the JTA-455 and the external device until you reach a comfortable listening level.

**Notes:**

1. If the line out jack of your external device is connected, then you only need to adjust the volume control of this system. If the Headphone Jack of your external device is connected, then you may need to adjust both the volume control of your external device and the volume control of this system to find the most desirable volume setting.
2. Once the AUX IN JACK (#13) is plugged, the unit will enter the AUX mode. Remember to disconnect the connection cable from the JTA-455 after use in order to be able to listen to the record from the Turntable.
3. Turn Off the JTA-455 when you finish listening. Don't forget to switch off the power on your external device as well.

## LINE-OUT CONNECTION

You can connect the JTA-455 to your home stereo system, or an external Hi-Fi / AMPLIFIER system by connecting the RCA LINE-OUT JACKS (#12) to the auxiliary input jacks on your home stereo/ Hi-Fi / Amplifier system using RCA cables (not included).



**Note:** The Volume Control on the JTA-455 will not alter the audio output level when using the LINE-OUT jacks.

## CONNECTING TO A COMPUTER FOR RECORDING

Before getting start, please install the “ AUDACITY ” recording software onto your computer. Below is an example using a computer with Microsoft XP and the Audacity software installed. For other Windows OS or Mac OS, please visit Audacity website for details. <http://audacity.sourceforge.net/>

### INSTALLING THE AUDACITY SOFTWARE

1. Insert the Audacity disc (included) into the CD drive of your computer.
2. Click on My computer on the desktop.
3. Double click CD drive to view the contents of the CD and select “Windows” under “Audacity” folder.
4. Open “Windows” folder and select “Audacity 2.0.3 (Windows 2000, XP, Vista, 7, 8)”.
5. Double click Audacity set up icon with file name “audacity-win-2.0.3” to install the Audacity software according to the instruction, read license agreements of Audacity before installation.

#### Note:

Free software (AUDACITY) licensed under the GNU general public license (GPL). More information as well as open source code can be found on the provided CD or on the website at: <http://audacity.sourceforge.net/>

### INSTALL THE USB DRIVE

1. Use the included USB cable to connect the turntable to your computer.
2. Your computer will detect the JTA-455 as a “USB PnP Audio Device” & start to install USB drivers for it automatically.
3. Waiting for the installation complete until your computer shows a pop up a message that it is installed properly and ready to use.

### SET RECORDING INPUT LEVEL (USING A WINDOWS XP COMPUTER)

1. Click the “Start“ in the left corner of your computer
2. Select “All Programs“ → “Accessories“ → “Entertainment“ → “Sound Recorder“ to open the sound record interface.

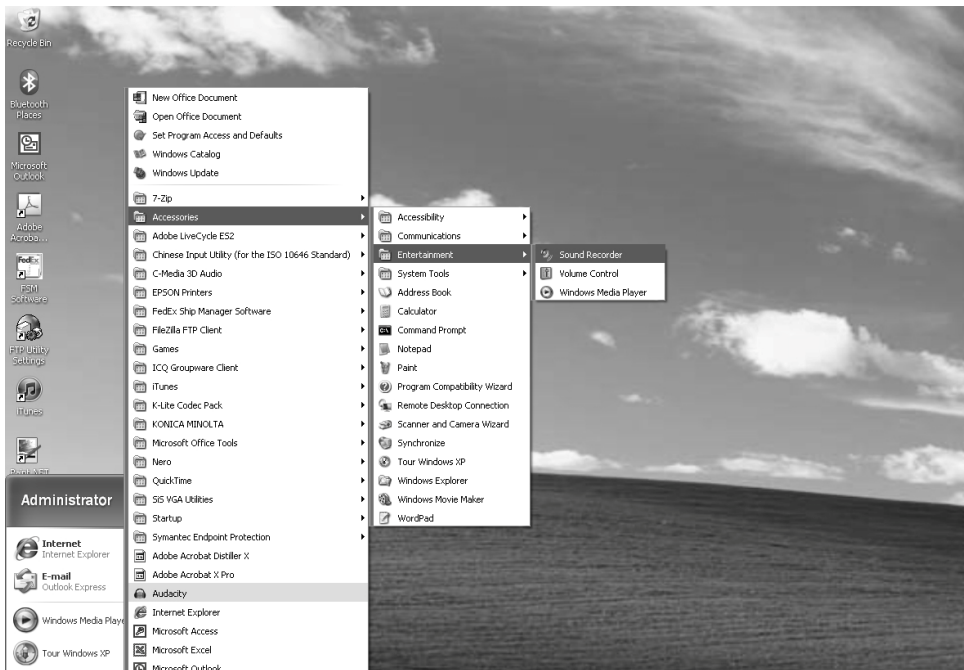

3. Select "Edit" and then click "Audio Properties" towards the bottom of the menu to select "Audio properties" interface.



4. In the Sound Recording field, click the pull down menu to select "USB PnP Audio Device" as Default device of sound recording.

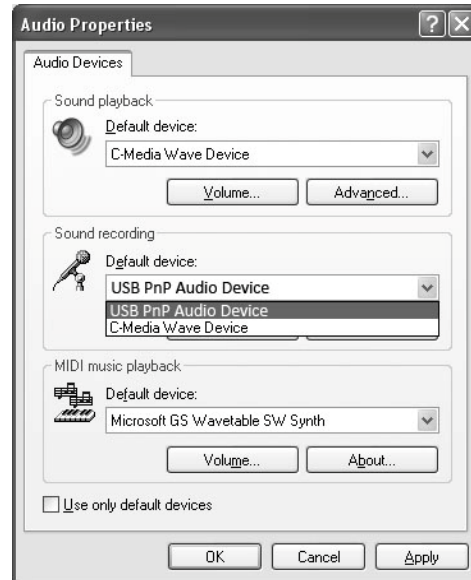

5. Click the Volume button under the Sound recording tab to open "Recording Control" interface;
6. Adjust the line in volume to a level without distortion. You can play a record on the turntable and use the Sound Recorder to record a short clip of music for testing. The sound wave will show on the interface screen when recording.

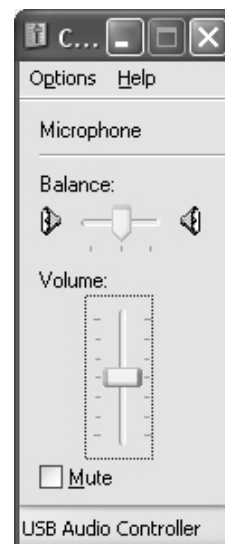

## RUNNING AUDACITY SOFTWARE

**Note:** Please review the software license and distribution restrictions found on the software disc. Use of the Audacity software is subject to those conditions and restriction. For additional help with recording and editing music by using the Audacity software, please visit <http://audacity.sourceforge.net/>

1. Run the Audacity from the Windows start menu or double click the Audacity icon on your computer desktop.
2. The Audacity main screen appears. You will find the Record, Play, Pause, Stop, Skip to Start and Skip to End control buttons here. Use the File, Edit, View, Transport, Tracks, Generate, Effect and Analyze menus from your computer screen to Save, Export or Edit the music.

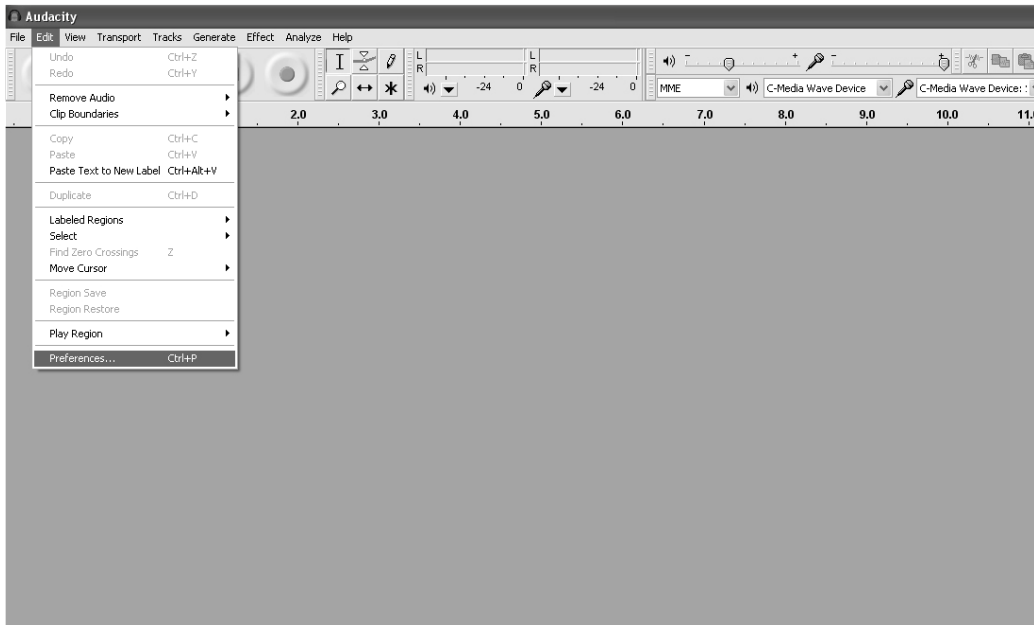

3. Click "Preferences" at the bottom of the Edit menu, you can set the Devices, Quality, and various settings here.

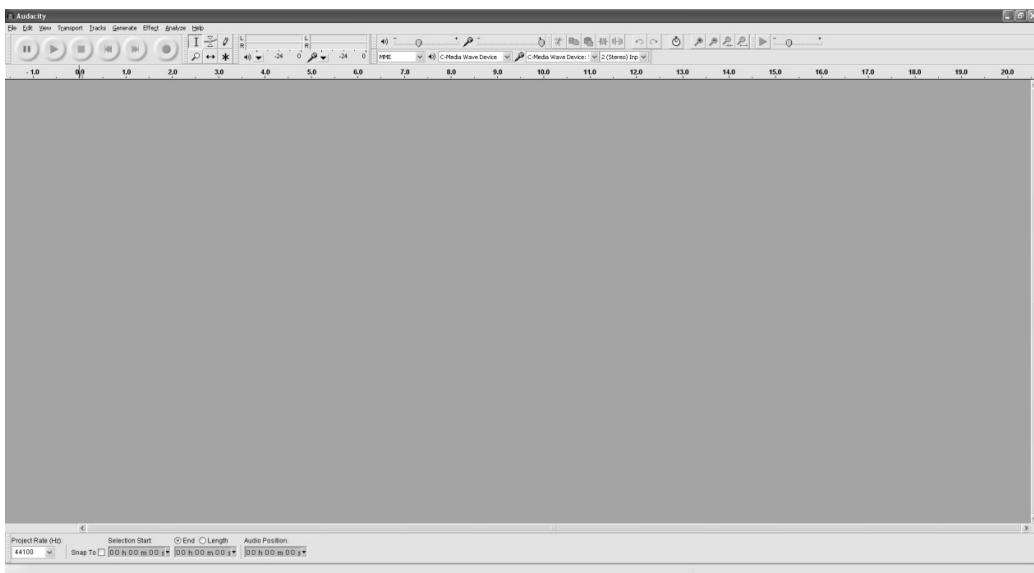

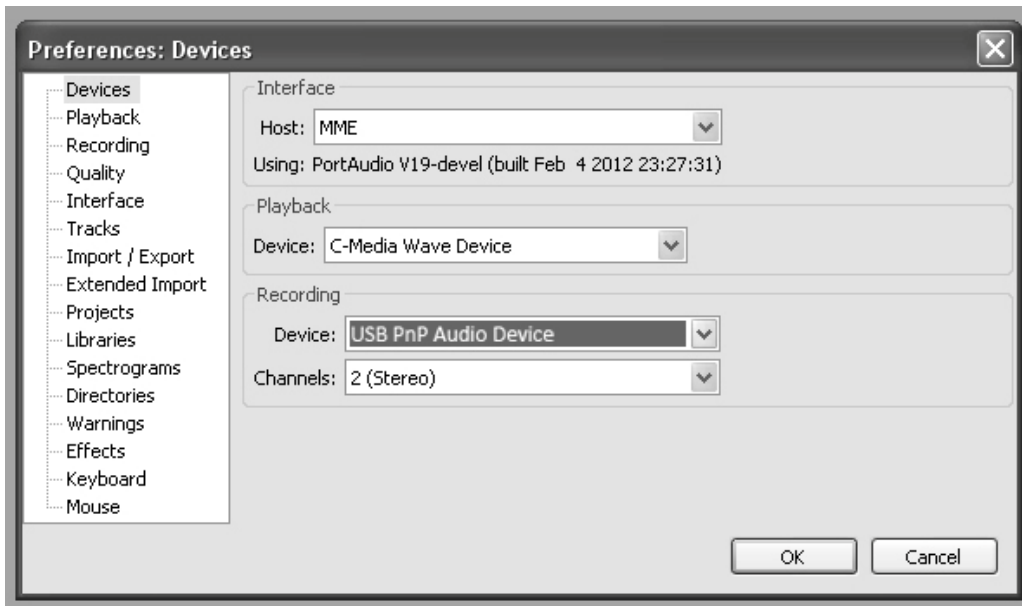

- Adjust the input and output volume by sliding the Input and Output Volume bars.

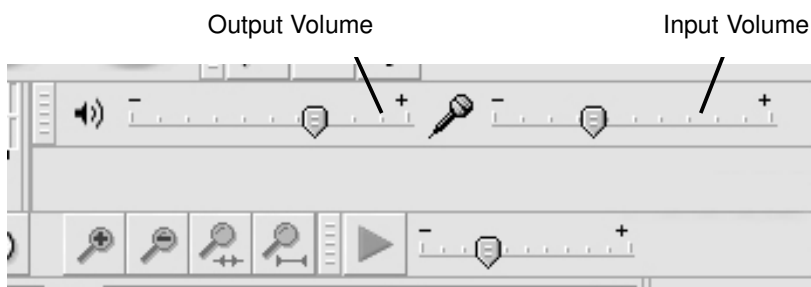

- Click the record button to start recording, left and right tracks will show on your computer screen. If you cannot see the sound waves appear on the Interface when recording, adjust the Input volume bar.

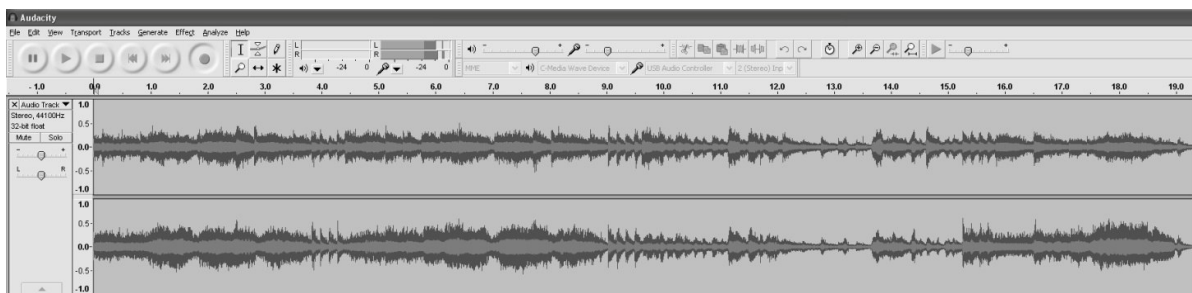

- Use the Audacity control panel to record or listen the music you have recorded
  - Click **●** button to start recording.
  - Click the **⏮** button to skip to start;
  - Click the **⏭** button to skip to end;
  - Click the **▶** button to play;
  - Click the **⏸** button to pause;
  - Click the **■** button to stop.



## EXPORT THE MUSIC FILES TO WAV OR MP3 FORMAT

Once you have finished recording, make sure you save your recorded music to the computer.

1. Click File menu and move down to “Export” to convert the file to WAV format or MP3 format.
2. Click on WAV or MP3 format you want to save the music as in pull down menu of “Save as type” field, and you will be asked for the file name of your recorded music.

**Note:** Audacity does not export MP3 files directly. If you want to encode your recorded music to MP3 format, you need to download the LAME MP3 encoder either in the CD provided or under the page “Other Audacity Downloads for Windows” of the website <http://audacity.sourceforge.net/>

## INSTALL THE MP3 ENCODER

1. Insert the included CD into your computer and select “Audacity 2.0(Windows 2000, XP, Vista, 7, 8)” under “Windows” folder.
2. Open the folder and select “Plug-ins”.
3. Double click the “Lame\_v3.99.3\_for\_windows.exe” file under “Plug-ins” folder to start install the program.

**Note:** Normally, Audacity will automatically locate the Lame file that you installed. However, if you change default directory of Lame program, you may need to manually locate it by using Audacity→Edit→Preference→Libraries and the click “Locate” button on computer screen to browse “lame\_enc.dll” file where the directory you have installed. See Fig.1 & 2 below and click OK to finish manual installation.

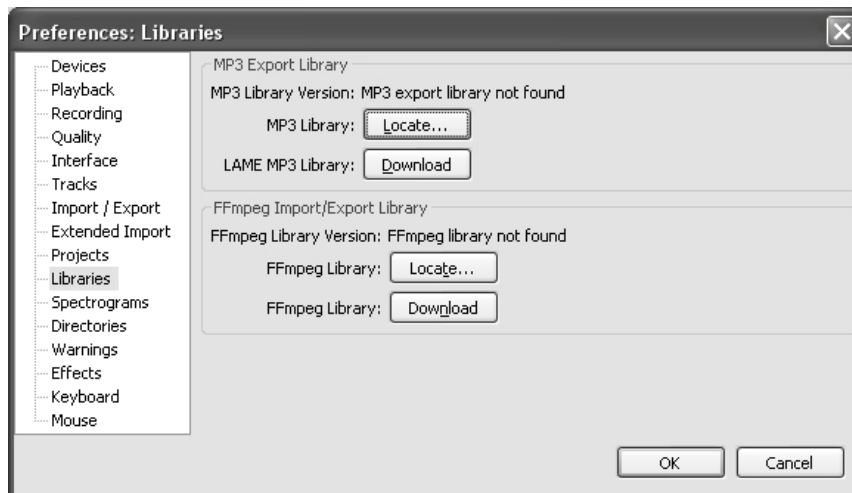

Fig. 1

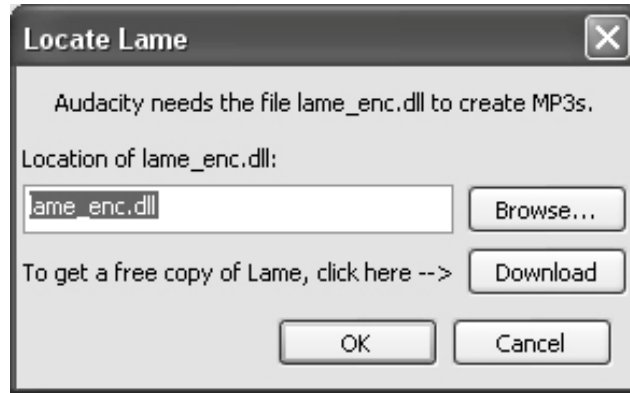

Fig.2

## CARE AND MAINTENANCE

1. Avoid operating your unit under direct sunlight or in hot, humid or dusty places.
2. Keep your unit away from heating appliances and sources of electrical noise such as fluorescent lamps or motors.
3. Unplug the unit from the electrical power outlet immediately in case of malfunction.

### CLEANING THE UNIT

- To prevent fire or shock hazard, disconnect your unit from the AC power source when cleaning.
- The finish on the unit may be cleaned with a dust cloth and cared for as other furniture, Use caution when cleaning and wiping the plastic parts.
- If the cabinet becomes dusty wipe it with a soft dry dust cloth. Do not use any wax or polish sprays on the cabinet.
- If the front panel becomes dirty or smudged with fingerprints it may be cleaned with a soft cloth slightly dampened with a mild soap and water solution. Never use abrasive cloths or polishes as these will damage the finish of your unit.

**CAUTION:** Never allow any water or other liquids to get inside the unit while cleaning.

## USING HEADPHONE (NOT INCLUDED)

You can enjoy the music personally by connect your headphones to the HEADPHONE JACK (#14) of the unit.

**Remark:** To avoid damage to your listening, please keep the volume level (8) at a low position during prolonged use of headphones.

## TROUBLESHOOTING GUIDE

SHOULD YOU EXPERIENCE DIFFICULTIES IN THE USE OF THIS PLAYER PLEASE REFER TO THE FOLLOWING CHART OR CALL 1-800-777-5331 FOR CUSTOMER SERVICE.

| PROBLEM                                  | POSSIBLE CAUSE  | SOLUTION   |
|--|---|--|
| The unit does not respond (no power).    | AC power cord is not plugged into a wall outlet or the connector is not plugged into the power supply jack on the back of the unit. | Plug the AC power cord into a wall outlet and plug the connector into the supply jack on the unit. |
|  | Wall outlet is not functioning.   | Plug another device into the same outlet to confirm the outlet is working.                         |
|  | POWER Switch in the OFF position  | Slide the POWER ON/OFF switch to the ON position   |
| Unit is ON but there is low or no volume | The volume Control has been turned all the way down   | Turn the Volume control to a higher output   |
| Sound is distorted.                      | Volume level is set too high  | Decrease the volume  |

## SPECIFICATIONS

**AC Power** AC 120V ~ 60Hz 12Watts

**System Requirement:** Windows 2000 / XP / Vista / 7 / 8  
Mac OS X 10.4 – 10.7.5

## SPECTRA GREEN NOTICE AND LICENSE



At Spectra, environmental and social responsibility is a core value of our business. We are dedicated to continuous implementation of responsible initiatives with an aim to conserve and maintain the environment through responsible recycling.

Please visit us at <http://www.spectraintl.com/green.htm> for more information on Spectra's green initiatives or to find a recycler in your area.

The *Bluetooth*® word mark and logos are registered trademarks owned by Bluetooth SIG, Inc. and any use of such marks by Spectra Merchandising Intl, Inc. is under license. Other trademarks and trade names are those of their respective owners.

## 90 DAY LIMITED WARRANTY AND SERVICE VALID IN THE U.S.A. ONLY

SPECTRA MERCHANDISING INTERNATIONAL, INC. warrants this unit to be free from defective materials or factory workmanship for a period of 90 days from the date of original customer purchase and provided the product is utilized within the U.S.A. This warranty is not assignable or transferable. Our obligation under this warranty is the repair or replacement of the defective unit or any part thereof, except batteries, when it is returned to the SPECTRA Service Department, accompanied by proof of the date of original consumer purchase, such as a duplicate copy of a sales receipt.

You must pay all shipping charges required to ship the product to SPECTRA for warranty service. If the product is repaired or replaced under warranty, the return charges will be at SPECTRA's expense. There are no other express warranties other than those stated herein.

This warranty is valid only in accordance with the conditions set forth below:

1. The warranty applies to the SPECTRA product only while:
  - a. It remains in the possession of the original purchaser and proof of purchase is demonstrated.
  - b. It has not been subjected to accident, misuse, abuse, improper service, usage outside the descriptions and warnings covered within the user manual or non-SPECTRA approved modifications.
  - c. Claims are made within the warranty period.
2. This warranty does not cover damage or equipment failure caused by electrical wiring not in compliance with electrical codes or SPECTRA user manual specifications, or failure to provide reasonable care and necessary maintenance as outlined in the user manual.
3. Warranty of all SPECTRA products applies to residential use only and is void when products are used in a nonresidential environment or installed outside the United States.

This warranty gives you specific legal rights, and you may also have other rights which vary from state to state. TO OBTAIN SERVICE please remove all batteries (if any) and pack the unit carefully and send it freight prepaid to SPECTRA at the address shown below. IF THE UNIT IS RETURNED WITHIN THE WARRANTY PERIOD shown above, please include a proof of purchase (dated cash register receipt) so that we may establish your eligibility for warranty service and repair of the unit without cost. Also include a note with a description explaining how the unit is defective. A customer service representative may need to contact you regarding the status of your repair, so please include your name, address, phone number and email address to expedite the process.

IF THE UNIT IS OUTSIDE THE WARRANTY PERIOD, please include a check for **\$55.00** to cover the cost of repair, handling and return postage. All out of warranty returns must be sent prepaid.

It is recommended that you contact SPECTRA first at 1-800-777-5331 or by email at [custserv@spectraintl.com](mailto:custserv@spectraintl.com) for updated information on the unit requiring service. In some cases the model you have may be discontinued, and SPECTRA reserves the right to offer alternative options for repair or replacement.

SPECTRA MERCHANDISING INTERNATIONAL, INC.  
4230 North Normandy Avenue,  
Chicago, IL60634, USA. 1-800-777-5331

To register your product, visit the link on the website below to enter your information.  
<http://www.spectraintl.com/wform.htm>