

Studebaker

Portable AM/FM Radio

SB2000 OWNER'S MANUAL



Please read this Instruction Manual carefully before using the unit and retain it for future reference

11. Protect the power cord from being walked on or pinched particularly at plugs, convenience receptacles, and the point where they exit from the apparatus.
12. Only use attachments/accessories specified by the manufacturer.
13. Unplug this apparatus during lightning storms or when unused for a long periods of time.
14. Refer all servicing to qualified service personnel. Servicing is required when the apparatus has been damaged in any way, such as power-supply cord or plug is damaged, liquid has been spilled or objects have fallen into the apparatus, the apparatus has been exposed to rain or moisture, does not operate normally, or has been dropped.
15. This appliance shall not be exposed to dripping or splashing water and that no object filled with liquids such as vases shall be placed on the apparatus.
16. Do not overload wall outlet. Use only power source as indicated.
17. Use replacement part as specified by the manufacturer.
18. Upon completion of any service or repairs to this product, ask the service technician to perform safety checks.
19. Power Sources - This product should be operated only from the type of power source indicated on the marking label. If you are not sure of the type of power supply to your home, consult your product dealer or local power company. For products intended to operate from battery power, or other sources, refer to the operating instruction.
20. Object and Liquid Entry - Never push objects of any kind into this product through openings as they may touch dangerous voltage points or short-out parts that could result in a fire or electric shock. Never spill liquid of any kind on the product.
21. Damage Requiring Service - Unplug this product from the wall outlet and refer servicing to qualified service personnel under the following conditions:
 - a) When the power-supply cord or plug is damaged,
 - b) If liquid has been spilled, or objects have fallen into the product,
 - c) If the product has been exposed to rain or water,
 - d) If the product does not operate normally by following the operating instructions. Adjust only those controls that are covered by the operating instructions as an improper adjustment of other controls may result in damage and will often require extensive work by a qualified technician to restore the product to its normal operation.
 - e) If the product has been dropped or damaged in any way, and
 - f) When the product exhibits a distinct change in performance - this indicates a need for service.
22. To be completely disconnected the power input, the mains plug of apparatus shall be disconnected from the mains.
23. The mains plug is used as disconnect device. The mains plug of apparatus should not be obstructed OR should be easily accessed during intended use.

 This symbol indicates that this product incorporates double insulation between hazardous mains voltage and user accessible parts.

 **CAUTION:**
TO PREVENT ELECTRIC SHOCK, MATCH WIDE BLADE OF PLUG TO WIDE SLOT. FULLY INSERT.

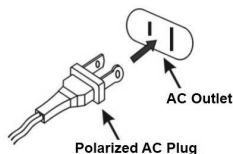

SAVE THESE INSTRUCTIONS

WARNING

TO PREVENT FIRE OR SHOCK HAZARD, DO NOT USE THIS PLUG WITH AN EXTENSION CORD, RECEPTACLE OR OTHER OUTLET UNLESS THE BLADES CAN BE FULLY INSERTED TO PREVENT BLADE EXPOSURE. TO PREVENT FIRE OR SHOCK HAZARD, DO NOT EXPOSE THIS APPLIANCE TO RAIN OR MOISTURE.



The lightning flash and arrow head within the triangle is a warning sign alerting you of "dangerous voltage" inside the product.

CAUTION
RISK OF ELECTRIC SHOCK
DO NOT OPEN

CAUTION: TO REDUCE THE RISK OF ELECTRIC SHOCK DO NOT REMOVE COVER (ON BACK), NO USER SERVICEABLE PARTS INSIDE. REFER SERVICING TO QUALIFIED SERVICE PERSONNEL.



The exclamation point within the triangle is a warning sign alerting you of important instructions accompanying the product.

The Caution Marking is located at the rear enclosure of the apparatus. The rating plate is located at bottom enclosure of the apparatus.

IMPORTANT SAFETY INSTRUCTIONS

1. Read these instructions.
2. Keep these instructions.
3. Heed all warnings.
4. Follow all instructions.
5. Do not use this apparatus near water.
6. Cleaning-Unplug this product from the wall outlet before cleaning. Do not use liquid cleaners or aerosol cleaners. Clean only with dry cloth.
7. Do not block any ventilation openings. Install in accordance with the manufacturer's instructions.
8. Do not place this product on an unstable cart, stand, tripod, bracket, or table. The product may fall, causing serious injury to a child or adult, and serious damage to the product. Use only with a cart, stand, tripod, bracket, or table recommended by the manufacturer, or sold with the product. Any mounting of the product should follow the manufacturer's instructions, and should use a mounting accessory recommended by the manufacturer. A product and cart combination should be moved with care-quick stops, excessive force and uneven surfaces may cause the product and cart combination to overturn.
9. Do not install near any heat sources such as radiators, heat registers, stoves, or other apparatus (including amplifiers) that product heat.
10. Do not defeat the safety purpose of the polarized or grounding-type plug. A polarized plug has two blades with one wider than the other. A grounding type plug has two blades and a third grounding prong. The wide blade or the third prong is provided for your safety. If the provided plug does not fit into your outlet, consult an electrician for replacement of the obsolete outlet.



COMPLIANCE WITH FCC REGULATIONS

This equipment has been tested and found to comply with the limits for a radio receiver, pursuant to Part 15 of the FCC Rules. These limits are designed to provide reasonable protection against harmful interference in a residential installation. This equipment generates, uses and can radiate radio frequency energy and, if not installed and used in accordance with the instructions, may cause harmful interference to radio communications. However, there is no guarantee that interference will not occur in a particular installation. If this equipment does cause harmful interference to radio or television reception, which can be determined by turning the equipment off and on, the user is encouraged to try to correct the interference by one or more of the following measures:

- Reorient or relocate the receiving antenna.
- Increase the separation between the equipment and receiver.
- Connect the equipment into an outlet on a circuit different from that to which the receiver is connected.
- Consult the dealer or an experienced radio technician for help.

WARNING

Changes or modifications to this unit not expressly approved by the party responsible for compliance could void the user's authority to operate the equipment.

PROTECT YOUR FURNITURE!!

This system is equipped with non-skid rubber 'feet' to prevent the product from moving when you operate the controls. These 'feet' are made from non-migrating rubber material specially formulated to avoid leaving any marks or stains on your furniture. However certain types of oil based furniture polishes, wood preservatives, or cleaning sprays may cause the rubber 'feet' to soften, and leave marks or a rubber residue on the furniture.

To prevent any damage to your furniture we strongly recommend that you purchase small self-adhesive felt pads, available at hardware stores and home improvement centers everywhere, and apply these pads to the bottom of the rubber 'feet' before you place the product on fine wooden furniture.

LOCATION AND DESCRIPTION OF CONTROLS

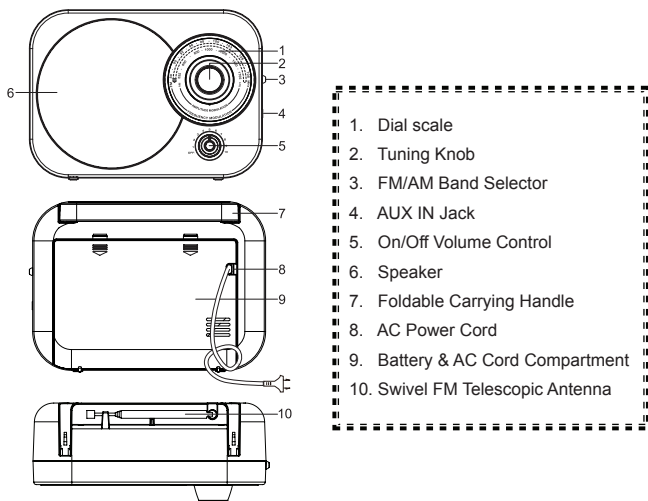

1. Dial scale
2. Tuning Knob
3. FM/AM Band Selector
4. AUX IN Jack
5. On/Off Volume Control
6. Speaker
7. Foldable Carrying Handle
8. AC Power Cord
9. Battery & AC Cord Compartment
10. Swivel FM Telescopic Antenna

POWER SUPPLY

The SB2000 can be operated from the following power sources:
 AC: 120V ~ 60 Hz
 DC: 4 x 1.5V , battery type R14/ UM-2/ "C" size (not provided)

CONNECTING TO AC POWER AND INSTALLING BATTERIES

1. Insert the plug of Power Cord into a standard wall outlet with a constant AC power supply.
2. Install 4 fresh alkaline batteries into the Battery Compartment following the polarity diagram inside. Use only the specified size and type of batteries.

IMPORTANT:

- Be sure that the battery is installed correctly. Wrong polarity may cause permanent damage to the unit.
- For best performance and longer operating time, we recommend the use of alkaline batteries.
- If the unit is not to be used for an extended period of time, remove all the batteries. Old or leaking battery can cause damage to the unit and will also void the warranty.
- Do not dispose of battery in fire. Battery may leak or explode.
- Battery shall not be exposed to excessive heat, such as sunshine, fire or the like.

E - 4

CAUTION:

Danger of explosion if batteries are incorrectly replaced. Replace only with the same or equivalent type.

Note:

When the unit is plugged into an AC outlet, it automatically switches to AC power source even if batteries are installed.

TURNING UNIT ON AND OFF

1. Rotate the On/Off Volume Control clockwise to turn on the unit, you will hear a "click" sound.
2. Rotate the On/Off Volume Control counter-clockwise to turn off the unit, a "click" sound is heard.

LISTENING TO THE RADIO

1. Use the Band Selector to choose the AM or FM band.
2. Turn on the radio by rotating the On/Off Volume Control clockwise.
3. Use the tuning knob to tune to your desired radio station.
4. Adjust the volume level.

HINTS FOR BEST RECEPTION:

- AM - The AM antenna is located inside the cabinet of the unit. If AM reception is weak, change the position of unit until the internal antenna picks up the strongest signal.
 FM - To insure maximum FM tuner reception, fully extend the FM telescopic antenna and rotate it for the best FM radio reception.

LISTENING TO AN AUXILIARY AUDIO SOURCE

This unit provides an auxiliary audio signal input jack for connecting external audio devices like MP3 players, CD players, smart phones and iPods (except iPod shuffle 3rd generation) to listen to your external source through the speakers of this system.

1. You need an audio cable (not included) with one 3.5 mm stereo plug on each end of the cable.
2. Plug one end of the cable into the AUX-IN jack located on the right hand side of the unit and the other end of the cable into the Line-out Jack or Headphone Jack of your external audio device.
3. Turn on the external audio device.
4. Turn on your unit and it will switch to AUX mode automatically.
5. The volume level can now be controlled through the volume control of your radio. Operate all other functions on the auxiliary device as usual.

Note:

- (1) If you connected the Line-out Jack of your external device then you only need to adjust the volume control of this system. If you connected the Headphone Jack of your external device then you may need to adjust both the volume control of your external device and the volume control of this system to find the most desirable volume setting.
- (2) Remove the audio cable from AUX IN jack when you finish listening. Don't forget to switch off the power on your external device as well.

E - 5

SPECIFICATIONS

POWER SUPPLY	AC - 120V ~ 60Hz, 4W DC - 4 x 1.5V type R14/ UM-2/ "C" size batteries (not provided)
FREQUENCY RANGE	FM 88 -108 MHz AM 535 -1705 kHz

TROUBLESHOOTING GUIDE

If you experience difficulties in the use of this music system, please check the following or call 1-800-777-5331 for Customer Service.

Symptom	Possible Cause	Solution
Noise or sound distorted on AM or FM broadcast.	- Station not tuned properly for AM or FM. - FM: Telescopic antenna is not extended. - AM: The bar antenna is not positioned correctly.	- Retune the AM or FM broadcast station. - Fully extend the FM telescopic antenna. - Reposition the unit until the best reception is obtained.
AM or FM no sound.	- Unit not set to AM or FM band. - Volume at minimum.	- Slide the band selector to AM or FM position. - Increase Volume.

90 DAY LIMITED WARRANTY AND SERVICE VALID IN THE U.S.A. ONLY

SPECTRA MERCHANDISING INTERNATIONAL, INC. warrants this unit to be free from defective materials or factory workmanship for a period of 90 days from the date of original customer purchase and provided the product is utilized within the U.S.A. This warranty is not assignable or transferable. Our obligation under this warranty is the repair or replacement of the defective unit or any part thereof, except batteries, when it is returned to the SPECTRA Service Department, accompanied by proof of the date of original consumer purchase, such as a duplicate copy of a sales receipt.

You must pay all shipping charges required to ship the product to SPECTRA for warranty service. If the product is repaired or replaced under warranty, the return charges will be at SPECTRA's expense. There are no other express warranties other than those stated herein.

E - 6

This warranty is valid only in accordance with the conditions set forth below:

1. The warranty applies to the SPECTRA product only while:
 - a. It remains in the possession of the original purchaser and proof of purchase is demonstrated.
 - b. It has not been subjected to accident, misuse, abuse, improper service, usage outside the descriptions and warnings covered within the user manual or non-SPECTRA approved modifications.
 - c. Claims are made within the warranty period.
2. This warranty does not cover damage or equipment failure caused by electrical wiring not in compliance with electrical codes or SPECTRA user manual specifications, or failure to provide reasonable care and necessary maintenance as outlined in the user manual.
3. Warranty of all SPECTRA products applies to residential use only and is void when products are used in a nonresidential environment or installed outside the United States.

This warranty gives you specific legal rights, and you may also have other rights which vary from state to state. TO OBTAIN SERVICE please remove all batteries (if any) and pack the unit carefully and send it freight prepaid to SPECTRA at the address shown below. IF THE UNIT IS RETURNED WITHIN THE WARRANTY PERIOD shown above, please include a proof of purchase (dated cash register receipt) so that we may establish your eligibility for warranty service and repair of the unit without cost. Also include a note with a description explaining how the unit is defective. A customer service representative may need to contact you regarding the status of your repair, so please include your name, address, phone number and email address to expedite the process.

IF THE UNIT IS OUTSIDE THE WARRANTY PERIOD, please include a check for **\$10.00** to cover the cost of repair, handling and return postage. All out of warranty returns must be sent prepaid.

It is recommended that you contact SPECTRA first at 1-800-777-5331 or by email at custserv@spectrainl.com for updated information on the unit requiring service. In some cases the model you have may be discontinued, and SPECTRA reserves the right to offer alternative options for repair or replacement.

SPECTRA MERCHANDISING INTERNATIONAL, INC.
 4230 North Normandy Avenue,
 Chicago, IL 60634, USA.
 1-800-777-5331

To register your product, visit the link on the website below to enter your information.
<http://www.spectrainl.com/wform.htm>

0316

Printed in China

E - 7