

MODEL JMC-180A

**WALL MOUNTABLE CD SYSTEM WITH
DIGITAL AM/FM STEREO RECEIVER**



**PLEASE READ THIS USER MANUAL COMPLETELY BEFORE
OPERATING THIS UNIT AND RETAIN THIS BOOKLET FOR
FUTURE REFERENCE.**

WARNING

TO PREVENT FIRE OR SHOCK HAZARD, DO NOT USE THIS PLUG WITH AN EXTENSION CORD, RECEPTACLE OR OTHER OUTLET UNLESS THE BLADES CAN BE FULLY INSERTED TO PREVENT BLADE EXPOSURE. TO PREVENT FIRE OR SHOCK HAZARD, DO NOT EXPOSE THIS APPLIANCE TO RAIN OR MOISTURE.



The Caution Marking is located at the back enclosure of the apparatus.

The Rating plate is located at the back enclosure of the apparatus

IMPORTANT SAFETY INSTRUCTIONS

1. Read these instructions.
2. Keep these instructions.
3. Heed all warnings.
4. Follow all instructions.
5. Do not use this apparatus near water.
6. Cleaning-Unplug this product from the wall outlet before cleaning. Do not use liquid cleaners or aerosol cleaners. Clean only with dry cloth.
7. Do not block any ventilation openings. Install in accordance with the manufacturer's instructions.
8. Do not place this product on an unstable cart, stand, tripod, bracket, or table. The product may fall, causing serious injury to a child or adult, and serious damage to the product. Use only with a cart, stand, tripod, bracket, or table recommended by the manufacturer, or sold with the product. Any mounting of the product should follow the manufacturer's instructions, and should use a mounting accessory recommended by the manufacturer. A product and cart combination should be moved with care-quick stops, excessive force and uneven surfaces may cause the product and cart combination to overturn.
9. Do not install near any heat sources such as radiators, heat registers, stoves, or other apparatus (including amplifiers) that product heat.
10. Do not defeat the safety purpose of the polarized or grounding-type plug. A polarized plug has two blades with one wider than the other. A grounding type plug has two blades and a third grounding prong. The wide blade or the third prong is provided for your safety. If the provided plug does not fit into your outlet, consult an electrician for replacement of the obsolete outlet.
11. Protect the power cord from being walked on or pinched particularly at plugs, convenience receptacles, and the point where they exit from the apparatus.
12. Only use attachments/accessories specified by the manufacturer.
13. Unplug this apparatus during lightning storms or when unused for a long periods of time.



14. Refer all servicing to qualified service personnel. Servicing is required when the apparatus has been damaged in any way, such as power-supply cord or plug is damaged, liquid has been spilled or objects have fallen into the apparatus, the apparatus has been exposed to rain or moisture, does not operate normally, or has been dropped.
15. This appliance shall not be exposed to dripping or splashing water and that no object filled with liquids such as vases shall be placed on the apparatus.
16. Do not overload wall outlet. Use only power source as indicated.
17. Use replacement part as specified by the manufacturer.
18. The product may be mounted to a wall only if recommended by the manufacturer.
19. Upon completion of any service or repairs to this product, ask the service technician to perform safety checks.
20. Power Sources - This product should be operated only from the type of power source indicated on the marking label. If you are not sure of the type of power supply to your home, consult your product dealer or local power company. For products intended to operate from battery power, or other sources, refer to the operating instruction.
21. Object and Liquid Entry - Never push objects of any kind into this product through openings as they may touch dangerous voltage points or short-out parts that could result in a fire or electric shock. Never spill liquid of any kind on the product.
22. Damage Requiring Service - Unplug this product from the wall outlet and refer servicing to qualified service personnel under the following conditions:
 - a) When the power-supply cord or plug is damaged,
 - b) If liquid has been spilled, or objects have fallen into the product,
 - c) If the product has been exposed to rain or water,
 - d) If the product does not operate normally by following the operating instructions. Adjust only those controls that are covered by the operating instructions as an improper adjustment of other controls may result in damage and will often require extensive work by a qualified technician to restore the product to its normal operation.
 - e) If the product has been dropped or damaged in any way, and
 - f) When the product exhibits a distinct change in performance - this indicates a need for service.
23. Main plug is used as disconnect device and it should remain readily operable during intended use. In order to disconnect the apparatus from the mains completely, the mains plug should be disconnected from the mains socket outlet completely.
24. Battery shall not be exposed to excessive heat such as sunshine, fire or the like.
25. Excessive sound pressure from earphones and headphone can cause hearing loss.

CAUTION:
TO PREVENT ELECTRIC SHOCK,
MATCH WIDE BLADE OF AC PLUG TO WIDE SLOT.
FULLY INSERT.

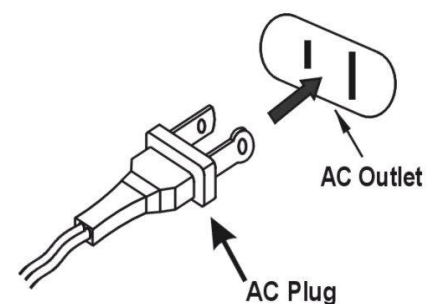

SAVE THESE INSTRUCTIONS

CAUTION

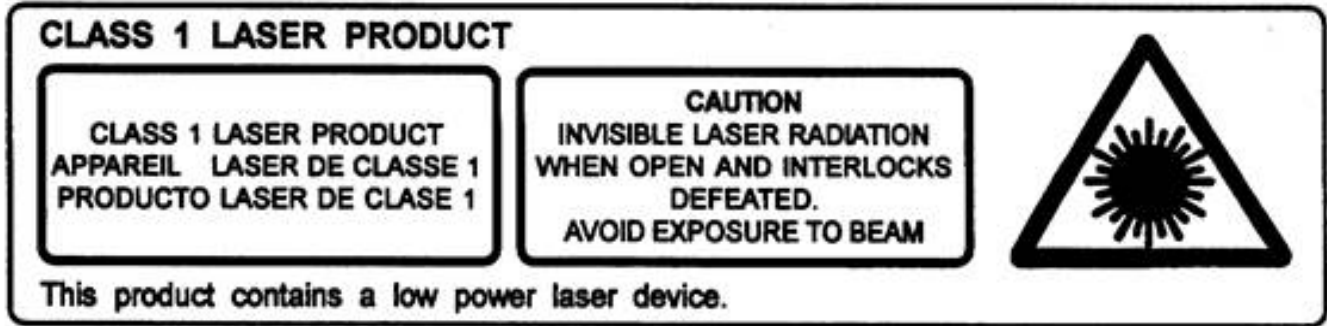

Follow the advice below for safe operations.

ON PROTECTION AGAINST LASER ENERGY EXPOSURE

- As the laser beam used in this compact disc player is harmful to the eyes, do not attempt to disassemble the casing.
- Stop operation immediately if any liquid or solid object should fall into the cabinet.
- Do not touch the lens or poke at it. If you do, you may damage the lens and the player may not operate properly.
- Do not put anything in the safety slot. If you do, the laser diode will be ON when the CD door is still open.
- If the unit is not to be used for a long period of time, make sure that all power sources are disconnected from the unit. Remove all batteries from the battery compartment.
- This unit employs a laser. The use of controls or adjustment or performance of procedures other than those specified here may result in exposure to hazardous radiation.

Should any trouble occur, remove the power source and refer servicing to qualified personnel.

COMPLIANCE WITH FCC REGULATIONS

This equipment has been tested and found to comply with the limits for a Class B Digital Device, pursuant to Part 15 of the FCC Rules. These limits are designed to provide reasonable protection against harmful interference in a residential installation. This equipment generates, uses and can radiate radio frequency energy and, if not installed and used in accordance with the instructions, may cause harmful interference to radio communications. However, there is no guarantee that interference will not occur in a particular installation. If this equipment does cause harmful interference to radio or television reception, which can be determined by turning the equipment off and on, the user is encouraged to try to correct the interference by one or more of the following measures:

- Reorient or relocate the receiving antenna.
- Increase the separation between the equipment and receiver.
- Connect the equipment into an outlet on a circuit different from that to which the receiver is connected.
- Consult the dealer or an experienced radio/TV technician for help.

WARNING

Changes or modifications to this unit not expressly approved by the party responsible for compliance could void the user's authority to operate the equipment.

Dear JENSEN Customer

Selecting fine audio equipment such as the unit you've just purchased is only the start of your musical enjoyment. Now it's time to consider how you can maximize the fun and excitement your equipment offers. This manufacturer and the Electronic Industries Association's Consumer Electronics Group want you to get the most out of your equipment by playing it at a safe level. One that lets the sound come through loud and clear without annoying blaring or distortion and, most importantly, without affecting your sensitive hearing. Sound can be deceiving. Over time your hearing "comfort level" adapts to higher volumes of sound. So what sounds "normal" can actually be loud and harmful to your hearing. Guard against this by setting your equipment at a safe level BEFORE your hearing adapts.

To establish a safe level:

- Start your volume control at a low setting.
- Slowly increase the sound until you can hear it comfortably and clearly, and without distortion.
- Once you have established a comfortable sound level: Set the dial and leave it there.

Take a minute to do this now will help to prevent hearing damage or loss in the future. After all, we want you listening for a lifetime.

We Want You Listening For a Lifetime

Used wisely, your new sound equipment will provide a lifetime of fun and enjoyment. Since hearing damage from loud noise is often undetectable until it is too late, this manufacturer and the Electronic Industries Association's Consumer Electronics Group recommend you avoid prolonged exposure to excessive noise.



Customer's Record:

The serial number of this product is found on its bottom. You should note the serial number of this unit in the space provided as a permanent record of your purchase to aid in identification in the event of theft or loss.

Model Number: JMC-180A

Serial Number: _____

PROTECT YOUR FURNITURE!!

This system is equipped with non-skid rubber 'feet' to prevent the product from moving when you operate the controls. These 'feet' are made from non-migrating rubber material specially formulated to avoid leaving any marks or stains on your furniture. However certain types of oil based furniture polishes, wood preservatives, or cleaning sprays may cause the rubber 'feet' to soften, and leave marks or a rubber residue on the furniture. To prevent any damage to your furniture we strongly recommend that you purchase small self-adhesive felt pads, available at hardware stores and home improvement centers everywhere, and apply these pads to the bottom of the rubber 'feet' before you place the product on fine wooden furniture.

LOCATION OF CONTROLS

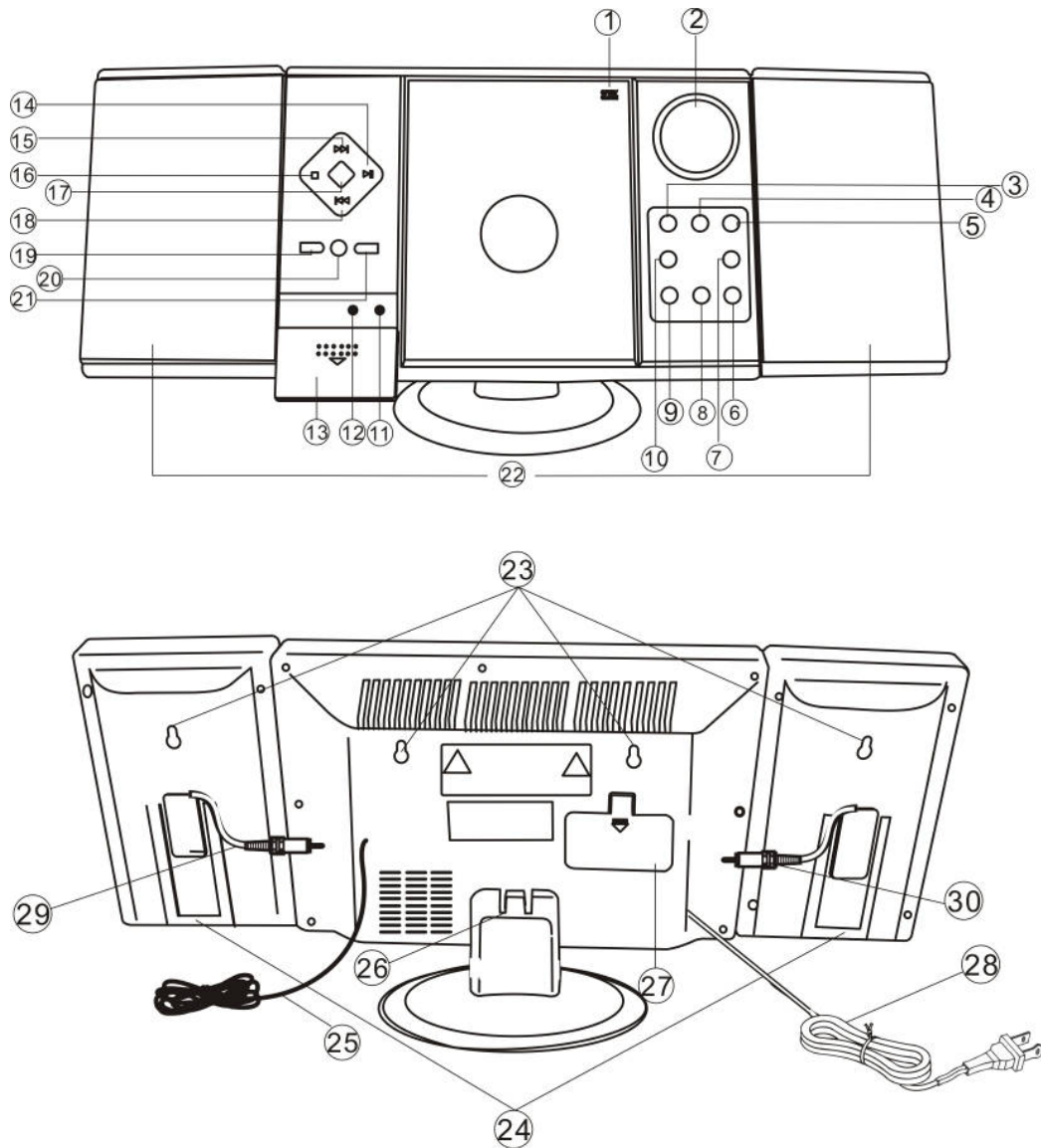

1	CD DOOR (OPEN/CLOSE)	11	AUX IN JACK	21	PROG. / PRESET + BUTTON
2	LCD DISPLAY	12	HEADPHONE JACK	22	SPEAKERS
3	TUNING - BUTTON	13	DOOR	23	HANGER HOLES
4	TUNING + BUTTON	14	PLAY/PAUSE / SCAN BUTTON	24	FOLD OUT SPEAKER STANDS
5	STANDBY BUTTON	15	SKIP/SEARCH FORWARD BUTTON	25	FM ANTENNA
6	TIME ADJ BUTTON	16	STOP / MEM. BUTTON	26	REMOVABLE STAND
7	AL. ON/OFF / SLEEP BUTTON	17	MODE BUTTON	27	BATTERY DOOR
8	VOL + / MIN. BUTTON	18	SKIP/SEARCH BACKWARD BUTTON	28	AC POWER CORD
9	VOL - / HOUR BUTTON	19	REPEAT / PRESET - BUTTON	29	SPEAKER CABLE
10	AL. SET / AM/FM BUTTON	20	REMOTE SENSOR	30	SPEAKER CABLE

REMOTE CONTROL

1	STANDBY BUTTON	7	MODE BUTTON
2	PLAY/PAUSE / SCAN BUTTON	8	MUTE BUTTON
3	STOP / MEM. BUTTON	9	SKIP/SEARCH FORWARD / TUNING + BUTTON
4	VOL - BUTTON	10	SKIP/SEARCH BACKWARD / TUNING - BUTTON
5	REPEAT / RANDOM / PRESET - BUTTON	11	VOL + BUTTON
6	NUMERIC BUTTONS	12	PROG / PRESET + BUTTON

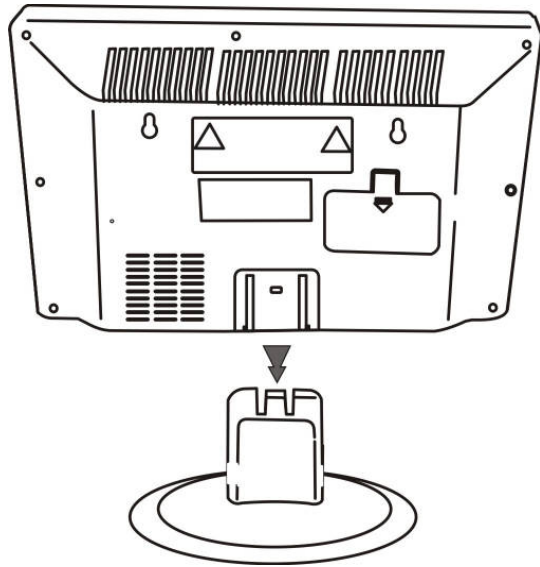
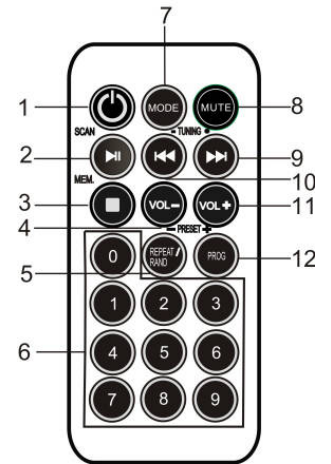

INSTALLING STAND

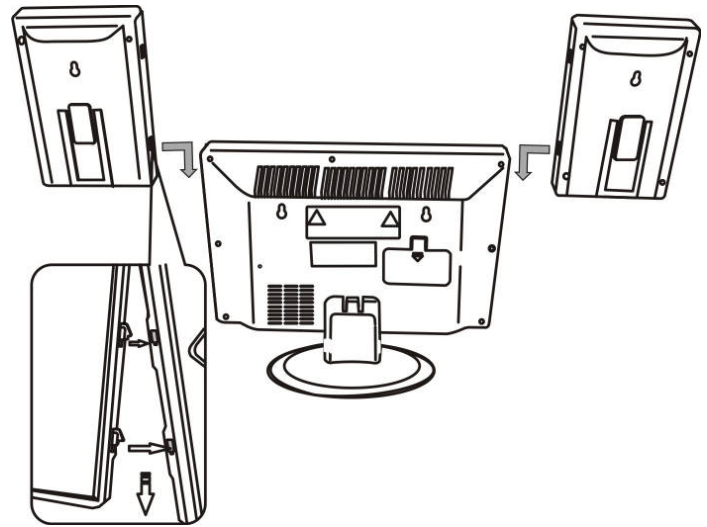

INSTALLING SPEAKER

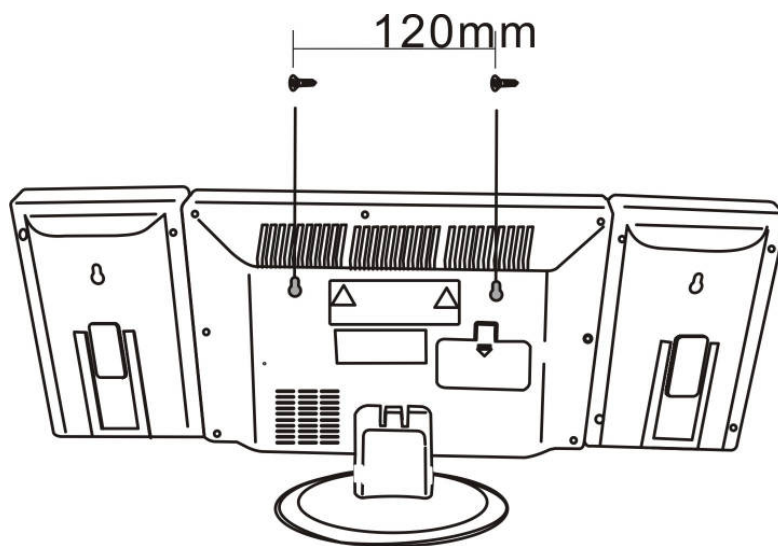

WALL MOUNTING

IMPORTANT NOTES

Avoid installing the unit in locations described below:

- Places exposed to direct sunlight or close to heat radiating appliances such as electric heaters.
- Dusty places.
- Places subject to constant vibration.
- Humid or moist places.

POWER SOURCES

This Music System operates on 120V~ 60Hz. Do not attempt to operate the radio on any other power source. You could cause damage to the unit and void your warranty.

Please be sure the power outlet you plug this unit into is working and receives constant (unswitched) power. The system is also equipped with a battery back-up system for the clock that is powered by 2 pieces of "AA" (UM-3) size batteries (Not included).

Note: The batteries may be installed as a backup option to maintain the clock time if electrical power fails. In the event of power outage, the clock time will not be displayed, however the clock will continue to operate so current time will be maintained.

The remote control unit it is designed to operate on 1 x CR2025 battery.

GETTING STARTED

A. INSTALLING BACK UP BATTERIES INTO THE SYSTEM

1. Remove the BATTERY DOOR.
2. Install 2 x "AA" (UM-3) batteries (not included) according to the polarity diagram inside the battery compartment.
3. Close the BATTERY DOOR.

Note : The backup battery is only for the Clock Setting and cannot backup the Alarm Setting.

B. INSTALLING BATTERIES INTO THE REMOTE CONTROL

The remote control operates on one CR2025 battery (included). To activate the remote control, remove the insulation tab inserted in the battery compartment. When the operation of the remote control becomes intermittent or unsatisfactory, replace the original battery with a new CR2025 lithium battery.

- 1.) Slide out the battery holder from the remote control case.
- 2.) Replace the 3V CR2025 battery. Be sure the battery is installed correctly.
The remote will not work if the battery is installed with the wrong polarity.
- 3.) Insert the battery holder back into the battery slot.

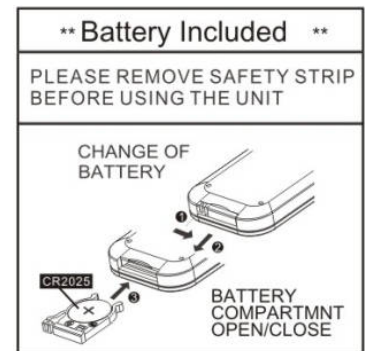

⚠ WARNING : DO NOT INGEST BATTERY, CHEMICAL BURN HAZARD.

The remote control supplied with this product contains a coin/button cell battery. If the coin/button cell battery is swallowed, it can cause severe internal burns in just 2 hours and can lead to death.

Keep new and used batteries away from children. If the battery compartment does not close securely, stop using the product and keep it away from children.

If you think batteries might have been swallowed or placed inside any part of the body, seek immediate medical attention.

IMPORTANT : Be sure that the batteries are installed correctly. Wrong polarity may damage the unit and void the warranty. For best performance and longer operating time, we recommend the use of good quality alkaline type batteries.

BATTERY CARE

- Do not mix old and new batteries.
- Do not mix alkaline, standard (carbon-zinc) or rechargeable (nickel-cadmium) batteries.
- If the unit is not to be used for an extended period of time, remove the battery. Old or leaking battery can cause damage to the unit and may void the warranty.
- Do not dispose of batteries in fire, batteries may explode or leak.

AC OPERATION

1. Plug the AC POWER CORD (#28) into a 120V AC ~ 60Hz outlet.
2. Press the STANDBY BUTTON (#5) to turn the unit on. The LCD DISPLAY backlight will light up.
3. Press the STANDBY BUTTON (#5) again, the unit will witch to standby mode. The LCD backlight will go off and clock displayed.

USING THE REMOTE CONTROL CORRECTLY

Note: The Remote Control is only for operating the CD Player and Radio.

- Point the Remote Control at the remote SENSOR (IR) (#20) located on the front of the System.
- The functions of the remote buttons are the same as the corresponding controls on the main unit.
- The performance of the Infrared SENSOR may be degraded causing unreliable operation if there is strong ambient light source in the same room.
- The recommended effective distance for remote operation is about 10-15 feet.

SETTING THE CLOCK

The clock has to be set before using the system for the first time. When you plug the system into an AC outlet for the first time the clock display will show "12:00" and need to be set.

1. Press and hold the TIME ADJ button (#6), the hour and minute digits will flash.
2. Repeatedly press the HOUR button (#9) to set the correct Hour.
3. Repeatedly press the MIN button (#8) to set the correct Minutes.
4. Press the TIME ADJ button (#6) once to complete. The clock display will stop flashing.

NOTE

There is a PM INDICATOR located on the left-hand side of the clock display. Be sure to observe the PM indicator when setting the time to make sure the time is set correctly for AM or PM. If the PM indicator appears, the time displayed is "PM". If the PM indicator is not shown, the time displayed is "AM".

RADIO OPERATION

The following procedures can also be accomplished by using the remote control. Check the remote control diagram for the corresponding buttons.

1. Press the STANDBY button (#5) located at the front of the main unit to turn on the system.
2. Press the MODE button (#17) repeatedly to select RADIO mode.
3. Press the AM/FM button (#10) to select AM or FM band.
4. Repeatedly press the TUNING + (#4) button or TUNING - (#3) button to manually tune to a desired station.
5. To automatically search for stations with strong signals, press and hold either the TUNING + (#4) or TUNING - (#3) buttons until the frequency read out on display begins to scan then release the button. The tuner will stop on the first strong station signal it finds.
5. Adjust the sound level by pressing the VOLUME +/- buttons (#8 or #9).
6. Press the TIME ADJ (#6) to show the current time on display. The time will revert back to the station frequency after about 6 second.

Notes:

- Manual tune to select weaker stations that might be bypassed during automatic tuning.
- If the automatic tuning does not stop on the exact frequency of the station, for example, it stops on 100.9 MHz instead of 100.8 MHz, use the manual tuning method to "fine tune" to the exact frequency of the desired station.
- If a station is broadcasting in Stereo, the unit will automatically receive the stereo broadcast.

TIPS FOR BEST RECEPTION

AM - The AM antenna is located inside the cabinet of the main unit. If AM reception is weak, change the position of cabinet until the internal antenna picks up the strongest signal,

FM - During FM reception, always keep the FM Wire Antenna fully extended. If FM reception is weak try repositioning the FM Wire Antenna until you find the strongest signal.

Setting the Radio Station Presets

The unit allows you to store up to 20 FM stations and 20 AM stations for easy recall at any time.

- 1.) In the FM or AM mode, tune to the radio station you want to store in memory by using TUNING + (#4) or TUNING - (#3) buttons.
- 2.) Press **MEM (#16)** button. The preset channel number "P01" will be flashing on display.
- 3.) To change the preset channel number location, press the PRESET + (#21) or PRESET - (#19) buttons to step through the preset locations (P01 - P20).
- 4.) To confirm the preset location, press the **MEM** button.
- 5.) To store up to 20 FM and 20AM station presets, repeat steps 1 to 4 above.

Hints

This unit features an AUTO SEARCH function that will automatically save the first 20 strong stations found. To use this feature, make sure the unit is in Radio mode, select the FM or AM band, press the SCAN (#14) button, and the unit will scan from the lowest frequency to the highest frequency within the selected frequency band. The first strong radio stations found will be stored in the preset locations starting from P01.

Note:

1. There is a 5 seconds delay when programming, after 5 seconds, the unit will automatically switch back to normal tuner mode.
2. You can overwrite a present station by saving the new frequency in its place.

Recall Preset Radio Stations

- 1.) Set the unit to Radio FM or AM mode.
- 2.) Press the PRESET + (#21) or PRESET - (#19) buttons to select preset station. You also can direct enter the preset location number by using the remote control.

CD PLAYER OPERATION

NOTE:

- This unit not only plays commercial compact discs but also self-compiled CD-RW discs.
- Because of non-standardized format definition/production of CD-R/RW, playback quality & performance is not guaranteed.
- Manufacturer is not responsible for the playability of CD-R/RW due to recording conditions such as PC performance, writing software, media properties etc.
- Do not attach a label or seal to either side of the CD-R/RW disc. It may cause a malfunction.

The following procedures can also be accomplished by using the remote control. Check the remote control diagram for the corresponding buttons.

PLAY MODE

1. Press the STANDBY button (#5) located at the front of the main unit to turn on the system.
2. Press the MODE button (#17) repeatedly to select CD mode.
3. Open the CD DOOR by pressing the CD DOOR at the “OPEN/CLOSE” mark located on the CD door, load a CD with the label side facing upward and then close the CD door.
4. Playback will start from track 1 once the Player has finished reading the TOC. The PLAY/PAUSE INDICATOR “▶” will appear steadily on the LCD DISPLAY.
5. While playing, press the PLAY/PAUSE ▶|| button (#14) to pause, the PLAY/PAUSE INDICATOR “▶” will flash. Press the PLAY/PAUSE ▶|| button (#14) again to resume playing.
6. Adjust the VOLUME +/- buttons (#8 or #9) to the desired volume level.

REPEAT MODE

REPEAT 1

When the REPEAT button (#19) is pressed once, the repeat Indicator “” will appear and flash on the LCD DISPLAY. The current track will be played repeatedly.

REPEAT ALL

When the REPEAT button (#19) is pressed twice, the repeat indicator “” will appear steadily on the LCD DISPLAY. The whole disc will be played continuously.

RANDOM PLAY MODE

When the REPEAT button (#19) is pressed three times to enter Random Play Mode, RAND will appear on the LCD DISPLAY.

To Cancel Repeat or Random Function:

Press the REPEAT button (#19) repeatedly until the REPEAT indicator and RAND is gone.

SKIP AND SEARCH MODE

1. During Play or Pause mode, press the SKIP FORWARD ▶▶ or SKIP BACKWARD ◀◀ buttons to go to the next track or go back to the beginning of the current track.
2. During playback, press and hold the SEARCH FORWARD ▶▶ or SEARCH BACKWARD ◀◀ Buttons to search within the current track with audible high speed playback.

PROGRAM PLAY MODE

This function allows music tracks to be played in a programmed sequence.

NOTE: Program can only be set in STOP mode.

1. Press the PROG button (#21) once. Program Number, “P01” will display and PROGRAM INDICATOR, “PROG” will flash in the LCD DISPLAY.

2. Press the SKIP FORWARD ►► or SKIP BACKWARD ◀◀ BUTTON to select the track to be programmed.
3. Press the PROG button (#21) again to store the selection. The Program No. will advance to “P02” to prompt for the next input.
4. You may repeat steps #2 to #3 to program up to 20 tracks. As soon as you have entered the 20th track , the LCD DISPLAY will show “FUL”, indicating that program is full.
5. Press **the** PLAY button to complete and start program play. Press STOP button to stop program play.
6. You may use the REPEAT function to repeatedly play a certain track (Repeat 1) or all tracks (Repeat All) in the Program Play Mode.
7. The Player will stop when all the programmed tracks have been played through once. To replay program play, the PLAY/PAUSE ►|| Button.
8. To cancel program play, press the STOP ■ BUTTON twice while program play is running or open the CD DOOR in stop mode.
11. To turn the Player off, press the STANDBY button. The LCD DISPLAY backlight will go “off”.

AUXILIARY (AUX) OPERATION

You can play other music sources (iPod, MP3 player or other digital audio player) through the speakers of this System by connecting the AUX IN Jack to your external player’s line out or headphone jack.

1. The AUX IN and PHONES JACKS are covered by the DOOR (#13).
2. Slide the DOOR downwards, plug one end of an audio cable (not included) into the AUX IN Jack and the other end of the cable to the line out or headphone jack of your digital audio player.
3. Turn on the unit and press Mode button (#17) repeatedly to select “AUX” mode.
5. Play your digital audio player.
6. Adjust the VOLUME on the external audio player and the System until you reach a comfortable listening level.
7. Turn the System and your audio player off when you have finished listening and then unplug the audio cable.

MUTE SETTING

Press the MUTE button on the remote control to mute the sound from the speakers. The volume level will appear on the LCD display and flash.





To cancel the Mute function, press the MUTE button on the remote control again or press the Volume + or Volume – on main unit or remote control.

USING HEADPHONE (NOT INCLUDED)



Inserting the plug of your headphone into the System’s PHONE JACK will enable you to listen to the CD, radio or other music sources in private. When using headphone, the speakers will be automatically disconnected. Adjust the VOLUME +/- buttons (#8 or #9) to the desired volume level.

ALARM OPERATION



SETTING THE WAKE UP TIME

1. In Standby mode, press and hold the AL. SET button (#10) until the Hour & Minute digits in the LCD display flash.
2. Press the HOUR button (#9) and MINUTE button (#8) repeatedly to set the correct wake up time.
3. Press the AL. SET button (#10) once to confirm the alarm time.
4. The alarm time will stop flashing. The alarm indicator  will remain flashing.
5. Press the AL. SET button (#10) repeatedly to select the alarm type, CD Player, Radio or Alarm sound.
(Alarm  and CD icon on and flash for Wake to CD, Alarm  and FM or AM icon on and flash for Wake to Radio and only Alarm  on and flash for Wake to Alarm.)
6. Press and hold the AL. SET button (#10) 2 seconds, the setting will be stored. The setting will also be stored automatically after 5 seconds if no buttons are pressed.

WAKE TO RADIO

1. Press the STANDBY button (#5) to turn on the System. The LCD DISPLAY lights up.
2. Press the MODE button (#17) select Radio mode.
3. Tune to your desired station, and adjust the volume level that you wish to hear when the wake up time is reached.
4. Press the STANDBY button (#5) to turn off the System. Repeat SETTING THE WAKE UP TIME step 1 to 4.
5. Press the AL. SET button (#10) repeatedly to select Wake to Radio and store.
6. Press the AL.ON/OFF Button once to turn on the alarm function. The ALARM INDICATOR  will light up
7. At the selected wake up time the Radio will turn on and will play about 60 minutes and then shut off automatically.
8. To stop the radio before it shuts off, press STANDBY button (#5) once. The radio will stop but the alarm remains set and will turn the radio on again at the same time on the following day.
9. If you do not want the alarm to turn the System on the following day, press the AL.ON/OFF Button (#7) again to turn off the alarm function. The ALARM INDICATOR  will go off.

WAKE TO CD

1. Press the STANDBY button (#5) to turn on the System. The LCD DISPLAY lights up.
2. Insert a CD you want to play when the wake up time is reached.
3. Press the MODE button (#17) repeatedly to select CD mode.
4. Adjust the volume level that you wish to hear when the wake up time is reached then press the STANDBY button (#5) again to turn off the System.
5. Repeat SETTING THE WAKE UP TIME step 1 to 4.
6. Press AL. SET button (#10) repeatedly to select Wake to CD
7. Press the AL.ON/OFF Button once to turn on the alarm function. The ALARM INDICATOR  will light up.
8. At the selected wake up time the Radio will turn on and will play about 60 minutes and then shut off automatically.
9. To stop the CD before it shuts off, press STANDBY button (#5) once. The CD will stop but the alarm remains set and will turn the CD on again at the same time on the following day.
10. If you do not want the alarm to turn the System on the following day, press the AL.ON/OFF Button (#7) Button again to turn off the alarm function. The ALARM INDICATOR  goes off.

WAKE TO ALARM

1. Repeat SETTING THE WAKE UP TIME step 1 to 4.
2. Press AL. SET button (#10) repeatedly to select Wake to ALARM.
3. At the selected wake up time the alarm will sound for 60 minutes and turn off automatically.
4. To stop the Alarm before it shuts off, press the STANDBY button (#5) once. The Alarm will stop but the alarm remains set and will turn on again at the same time on the following day.
5. If you do not want the alarm to turn on the following day, press the AL.ON/OFF Button (#7) Button again to turn off the alarm function. The ALARM INDICATOR  will go off.



NOTE

There is a PM INDICATOR located on the left-hand side of the clock display. Be sure to observe the PM indicator when setting the alarm to make sure the alarm time is set correctly for AM or PM. If the PM indicator appears in LCD DISPLAY, the alarm will be "PM". If not, the alarm time will be "AM".

The Alarm function will be temporarily disabled when the system is turned On, and will resume again when set to Standby Mode.

Any time the system loses power or is disconnected from the AC outlet, the Alarm settings will be lost and will need to be reset once power is restored.

TURNING ALARM FUNCTION ON/OFF

1. Press the AL.ON/OFF Button (#7) once to turn the alarm function on. The ALARM INDICATOR  will appear in the DISPLAY.
2. Press the AL.ON/OFF Button (#7) again to turn the alarm function off. The ALARM INDICATOR  will disappear in the DISPLAY.

CHECKING THE WAKE UP TIME

Whenever you want to check the wake up time, simply press the AL SET button (#10) once while in Standby Mode. The display will change from current time to wake up time and last about 5 seconds.

SLEEP FUNCTION

This function allows you to program the system to turn itself OFF after a set period of time. You can set your sleep time while in Power ON mode:

1. To activate the sleep function, press the SLEEP button (#7) repeatedly on the unit, the display will show "OFF 120, 90, 60, 45, 30, 15" and SLEEP icon turn on.
2. When the display shows your desired sleep time, release the button, the sleep timer is now activated. The display show "15" is to indicate "15 minutes" sleep time and so on. When the sleep time counts to zero, the unit will go off.

CARE AND MAINTENANCE

1. Clean your unit with a damp (never wet) cloth. Solvent or detergent should never be used.
2. Avoid leaving your unit in direct sunlight or in hot, humid or dusty places.
3. Keep your unit away from heating appliances and sources of electrical noise such as fluorescent lamps or motors.
4. If drop-outs or interruptions occur in the music during CD play, or if the CD fails to play at all, its bottom surface may require cleaning. Before playing, wipe the disc from the center outwards with a good soft cleaning cloth.

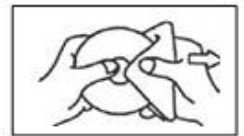

TROUBLESHOOTING GUIDE

If you experience difficulties in the use of this music system please check the following or call **1-800-777-5331** for Customer Service and Support.

Symptom	Possible Cause	Solution
Noise or sound distorted on AM or FM broadcast	<ul style="list-style-type: none"> - Station not tuned properly for AM or FM. - FM: FM Wire antenna is not extended. - AM: The bar antenna is not positioned correctly. 	<ul style="list-style-type: none"> - Retune the AM or FM broadcast station. - FM: Extend the FM Wire antenna - AM: Reposition the unit until the best reception is obtained.
AM or FM no sound	<ul style="list-style-type: none"> - Unit not in "RADIO" function mode. - Volume set at minimum 	<ul style="list-style-type: none"> - Slide FUNCTION SELECTOR to "RADIO" position. - Increase Volume.
CD player will not play	<ul style="list-style-type: none"> - Unit not in CD function mode. - CD is not loaded properly. - If the CD is self-compiled, the media used may not be compatible with the player. 	<ul style="list-style-type: none"> - Select CD function mode. - Load CD with label side up. - Use better quality blank media and Retest.
CD skips while playing	<ul style="list-style-type: none"> - Disc is dirty or scratched. 	<ul style="list-style-type: none"> - Wipe CD with clean cloth or use another disc.
Intermittent sound from CD player	<ul style="list-style-type: none"> - Dirty or defective disc. - Dirty pick up lens. - Player is subject to excessive shock or vibration. 	<ul style="list-style-type: none"> - Clean or replace the defective disc. - Use a CD lens cleaning disc to clean. - Relocate the player away from shock or vibration.
Sound appears distorted at high volume levels	<ul style="list-style-type: none"> - Volume control is set to maximum. 	<ul style="list-style-type: none"> - Adjust Volume Control to a lower comfortable level.
No Alarm Display	<ul style="list-style-type: none"> - Alarm is not activated. - Incorrect Alarm time. 	<ul style="list-style-type: none"> - Check that Alarm indicator "🔔" appears in the Display. - Make sure AM or PM is set correctly.

SPECTRA GREEN NOTICE



At Spectra, environmental and social responsibility is a core value of our business. We are dedicated to continuous implementation of responsible initiatives with an aim to conserve and maintain the environment through responsible recycling. Please visit us at <http://www.spectraintl.com/green.htm> for more information on Spectra's green initiatives or to find a recycler in your area.

90 DAY LIMITED WARRANTY AND SERVICE VALID IN THE U.S.A. ONLY

SPECTRA MERCHANDISING INTERNATIONAL, INC. warrants this unit to be free from defective materials or factory workmanship for a period of 90 days from the date of original customer purchase and provided the product is utilized within the U.S.A. This warranty is not assignable or transferable. Our obligation under this warranty is the repair or replacement of the defective unit or any part thereof, except batteries, when it is returned to the SPECTRA Service Department, accompanied by proof of the date of original consumer purchase, such as a duplicate copy of a sales receipt.

You must pay all shipping charges required to ship the product to SPECTRA for warranty service. If the product is repaired or replaced under warranty, the return charges will be at SPECTRA's expense. There are no other express warranties other than those stated herein.

This warranty is valid only in accordance with the conditions set forth below:

1. The warranty applies to the SPECTRA product only while:
 - a. It remains in the possession of the original purchaser and proof of purchase is demonstrated.
 - b. It has not been subjected to accident, misuse, abuse, improper service, usage outside the descriptions and warnings covered within the user manual or non-SPECTRA approved modifications.
 - c. Claims are made within the warranty period.
2. This warranty does not cover damage or equipment failure caused by electrical wiring not in compliance with electrical codes or SPECTRA user manual specifications, or failure to provide reasonable care and necessary maintenance as outlined in the user manual.
3. Warranty of all SPECTRA products applies to residential use only and is void when products are used in nonresidential environment or installed outside the United States.

This warranty gives you specific legal rights, and you may also have other rights which vary from state to state. TO OBTAIN SERVICE please remove all batteries (if any) and pack the unit carefully and send it freight prepaid to SPECTRA at the address shown below. IF THE UNIT IS RETURNED WITHIN THE WARRANTY PERIOD shown above, please include a proof of purchase (dated cash register receipt) so that we may establish your eligibility for warranty service and repair of the unit without cost. Also include a note with a description explaining how the unit is defective. A customer service representative may need to contact you regarding the status of your repair, so please include your name, address, phone number and email address to expedite the process.

IF THE UNIT IS OUTSIDE THE WARRANTY PERIOD, please include a check for **\$20.00** to cover the cost of repair, handling and return postage. All out of warranty returns must be sent prepaid.

It is recommended that you contact SPECTRA first at 1-800-777-5331 or by email at custserv@spectrainl.com for updated information on the unit requiring service. In some cases the model you have may be discontinued, and SPECTRA reserves the right to offer alternative options for repair or replacement.

SPECTRA MERCHANDISING INTERNATIONAL, INC.
4230 North Normandy Avenue,
Chicago, IL60634, USA. 1-800-777-5331

To register your product, visit the link on the website below to enter your information.
<http://www.spectrainl.com/wform.htm>

1113A

Printed in China