

# **JENSEN®** audio

**MODEL SAB-55**

## **DIGITAL AM/FM STEREO ARMBAND RADIO**

### **OPERATING INSTRUCTIONS**



PLEASE READ THIS OPERATING MANUAL COMPLETELY BEFORE OPERATING THIS UNIT AND RETAIN THIS BOOKLET FOR FUTURE REFERENCE.

# FUNCTIONS AND CONTROLS

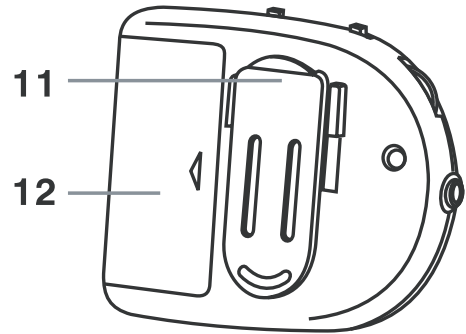
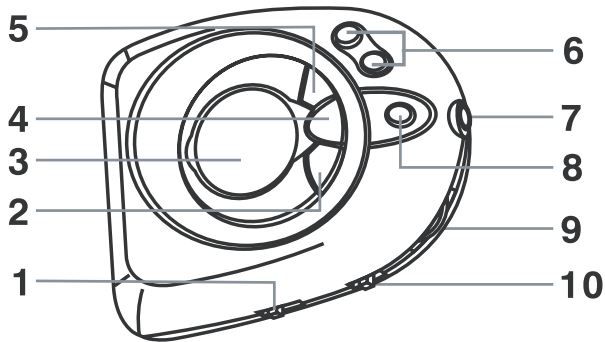

1. POWER SWITCH (LOCK/ON/OFF)
2. ▼ (TUNING DOWN/MINUTE)
3. LCD DISPLAY
4. BAND SELECTOR
5. ▲ (TUNING UP/HOUR)
6. MEMORY CHANNEL ▲ & MEMORY CHANNEL ▼
7. HEADPHONE JACK
8. MEMORY/TIME
9. VOLUME CONTROL
10. BASS BOOST SWITCH (BBS)
11. BELT CLIP
12. BATTERY COMPARTMENT DOOR
13. AM/FM INDICATOR
14. FM STEREO INDICATOR
15. LOW BATTERY ICON (  )
16. FREQUENCY READING
17. MEMORY INDICATOR
18. MEMORY CHANNEL NUMBER
19. LOCK INDICATOR
20. AM/PM INDICATOR
21. TIME READING

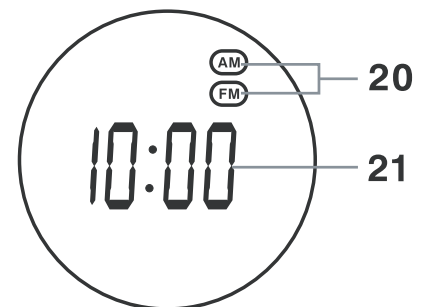
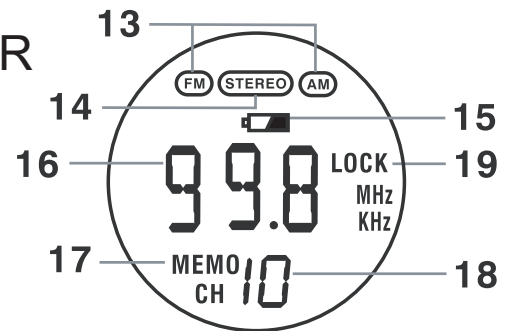

## POWER SOURCE

This DIGITAL AM/FM STEREO ARMBAND RADIO operates on 2 'AAA' (UM-4) batteries (not included).

## INSTALLING BATTERY

1. Remove the BATTERY DOOR (# 12).
2. Following the polarity diagram (+ and -) shown in the battery compartment, insert 2 'AAA' (UM-4) batteries.
3. Close the BATTERY DOOR (# 12).

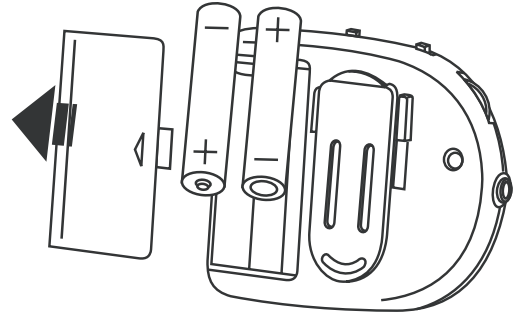

**IMPORTANT** : Be sure that the batteries are installed correctly.

Wrong polarity may damage the unit.

4. For better performance and longer operating time, we recommend the use of alkaline-type batteries.
5. Do not mix old and new batteries.
6. Do not mix alkaline, standard (carbon-zinc) or rechargeable (nickel-cadmium) batteries.
7. If the unit is not to be used for an extended period of time, remove the batteries. Old or leaking batteries can cause damage to the unit and may void the warranty.
8. Do not dispose of batteries in fire, batteries may explode or leak.

**Note:** i. Replace the batteries when the low battery icon (#15) flashes in the display.  
ii. To prevent memory loss, always replace the batteries in CLOCK mode.

## USING THE BELT CLIP

With the supplied BELT CLIP, you can wear your unit on a belt for convenient use.

### 1. Attaching the BELT CLIP

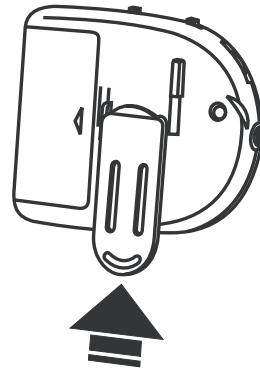

### 2. Removing the BELT CLIP

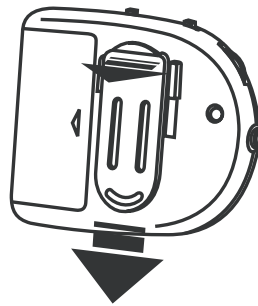

### 3. Position for attaching the unit with BELT CLIP

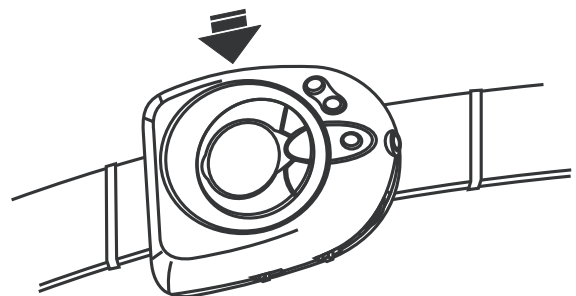

## USING THE ARMBAND

With the supplied ARMBAND, you can wear your unit on arm for convenient use.

### 1. Attaching the ARMBAND to the BELT CLIP

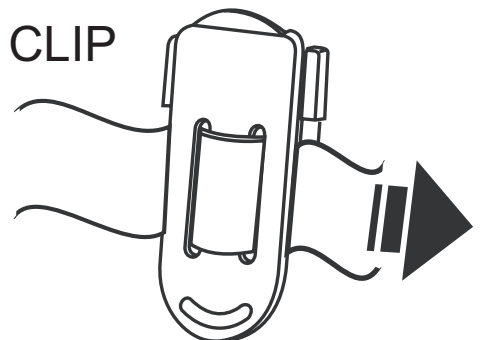

2. Attaching the BELT CLIP to your unit

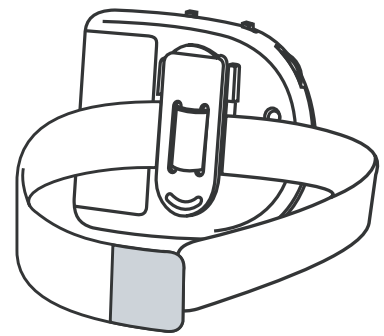

3. Adjusting the ARMBAND

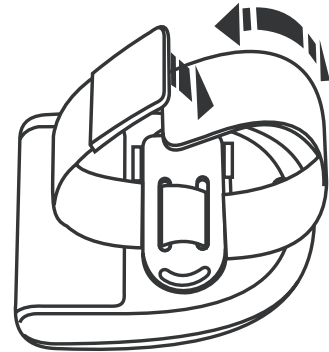

4. Wear on arm

**Note:** After fitting the band to your arm, the excess could be cut off to avoid rubbing under arm during physical activity.

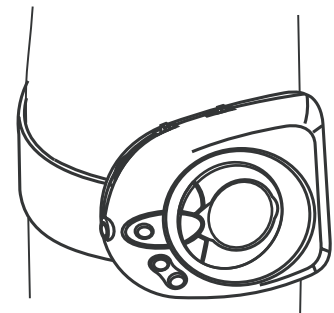

## **RADIO OPERATION**

### **A. AUTO TUNING FUNCTION**

1. Insert the earphone plug into the HEADPHONE JACK (# 7) on the unit.
2. To turn the unit on, slide the POWER Switch (# 1) to ON.
3. Set to FM or AM band by pressing the BAND Selector (# 4).

4. Press the ▼ (# 2) or ▲ Button (# 5) for 1 second and then release. The tuning will automatically search until a station is received and then stop. Anytime you want to stop tuning, press the ▼ (#2) or ▲ Button (# 5) once. **STEREO** (# 14) appears in the LCD PANEL (# 3) when an adequate FM STEREO signal is received. If the FM STEREO signal is weak, the FM STEREO INDICATOR (# 14) will flicker or will not appear in the LCD PANEL (# 3).
5. Adjust the VOLUME CONTROL (# 9) for desired listening level.
6. Slide the BBS (# 10) to ON to emphasize the bass sound.
7. To switch the radio off, slide the POWER Switch (# 1) to OFF and current time is displayed.

## **B. MANUAL TUNING FUNCTION**

If the station signal is not very strong or you want to fine tune the station, you may tune the station manually. Press the ▼ (# 2) or ▲ Button (# 5) and then release. The tuning will search step by step.

## **C. PRESETTING A STATION**

Up to 10 AM and 10 FM stations can be preset into the memory.

1. Slide the POWER Switch (# 1) to ON to turn the unit on.
2. Press the BAND Selector button (# 4) to select AM or FM band.
3. Tune to the desired station by pressing either the ▼ (# 2) or ▲ (# 5) Button.
4. Press the MEM/TIME Button (# 8) and **MEMO** (# 16) will blink in the LCD PANEL (# 3).
5. Press the MEM. CH ▲ or ▼ (# 6) Button to select the desired channel.

6. Press the MEM/TIME button (# 8) again to confirm the setting.
7. Follow the same procedure to set other stations into the remaining channels.

**Note:** If no buttons are pressed for approximately 5 seconds while the **MEMO** icon is flashing in the display, the setting procedure will stop and the unit will revert to normal display mode.

8. To change any of the stations stored in memory, simply enter a new station in the desired memory location. The previously stored station will be replaced by the new station.

#### **D. TO RECEIVE PRESET STATIONS**

1. Press the BAND Button (# 4) to select AM or FM band when the unit is on.
2. Press MEM. CH ▲ or ▼ Button (# 6) to select the preset channel.  
The station's frequency (# 15) and the Preset number (# 17) will appear in the LCD PANEL (# 3).
3. Adjust the VOLUME CONTROL (# 9) for the desired listening level.
4. Slide the BBS (# 10) to the ON position to emphasize the bass sound.
5. To switch the radio off, slide the POWER Switch (# 1) to OFF and current time is displayed.

- Note:**
- i. When listening to FM programs, the headphone cord works as an antenna. To insure maximum tuner sensitivity, always keep the headphone cord (antenna) straight. Do not fold it.
  - ii. When tuning in an AM station, be sure to place the set in the vertical position. For maximum AM sensitivity, keep turning the set slowly while keeping it vertical until the best reception is obtained.

## SETTING TIME

1. In current time mode, press the MEM./TIME Button (# 8) once. Clock digits flash.
2. Press HOUR Button (# 5) repeatedly until correct hour is displayed.
3. Press MINUTE Button (# 2) repeatedly until correct minute is displayed. Clock digits will stop flashing in 5 seconds and return to current time mode.

**Note:** The clock is of 12- hour format. Make sure the hour is set so that **AM** or **PM** (# 19) is correctly displayed.

## LOCK FUNCTION

To prevent accidental function changes during active use, this unit is fitted with a function lock. After the unit has been powered on and the required station tuned, slide the POWER Switch (# 1) to the LOCK position to lock all functions. **LOCK** icon (# 18) is displayed.

## CARE AND MAINTENANCE

1. Clean your unit with a damp (never wet) cloth. Solvent or detergent should never be used.
2. Avoid leaving your unit in direct sunlight or in hot, humid, or dusty places.
3. Keep your unit away from heating appliances and sources of electrical noise such as fluorescent lamps or motors.

## FCC NOTICE

This equipment has been tested and found to comply with the limits for a Radio Receiver, pursuant to Part 15 of the FCC Rules. These limits are designed to provide reasonable protection against harmful interference in a residential installation. This equipment generates, uses, and can radiate radio frequency energy and, if



not installed and used in accordance with the instructions, may cause harmful interference to radio communications. However, there is no guarantee that interference will not occur in a particular installation. If this equipment does cause harmful interference to radio or television reception, which can be determined by turning the equipment off and on, the user is encouraged to try to correct the interference by one or more of the following measures:

- Reorient or relocate the receiving antenna.
- Increase the separation between the equipment and receiver.
- Connect the equipment into an outlet on a circuit different from that to which the receiver is connected.
- Consult the dealer or an experienced radio technician for help.

**WARNING:**

Changes or modifications to this unit not expressly approved by the party responsible for compliance could void the user's authority to operate the equipment.

## 90 DAY LIMITED WARRANTY AND SERVICE VALID IN THE U.S.A ONLY

SPECTRA MERCHANDISING INTERNATIONAL, INC. warrants this unit to be free from defective materials or factory workmanship for a period of 90 days from the date of original customer purchase and provided the product is utilized within the U.S.A. This warranty is not assignable or transferable. Our obligation under this warranty is the repair or replacement of the defective unit or any part thereof, except batteries, when it is returned to the SPECTRA Service Department, accompanied by proof of the date of original consumer purchase, such as a duplicated copy of a sales receipt.

You must pay all shipping charges required to ship the product to SPECTRA for warranty service. If the product is repaired or replaced under warranty, the return charges will be at SPECTRA's expense. There are no other express warranties other than those stated herein.

This warranty is valid only in accordance with the conditions set forth below:

1. The warranty applies to the SPECTRA product only while:
  - a. It remains in the possession of the original purchaser and proof of purchase is demonstrated
  - b. It has not been subjected to accident, misuse, abuse, improper service, usage outside the descriptions and warnings covered within the owner's manual or non - SPECTRA approved modifications
  - c. Claims are made within the warranty period
2. This warranty does not cover damage or equipment failure caused by electrical wiring not in compliance with electrical codes or SPECTRA owner's manual specifications, or failure to provide reasonable care and necessary maintenance as outlined in the owner's manual.
3. Warranty of all SPECTRA products applies to residential use only and is void when products are used in a nonresidential environment or installed outside the United States.

This warranty gives you specific legal rights, and you may also have other rights which vary from state to state. TO OBTAIN SERVICE please remove all batteries (if any) and pack the unit carefully and send it prepaid by insured parcel post or UPS to SPECTRA at the address shown below. IF THE UNIT IS RETURNED WITHIN THE WARRANTY PERIOD shown above, please include a proof of purchase (dated cash register receipt) so that we may establish your eligibility for warranty service and repair of the unit without cost. Also include a note with a description explaining how the unit is defective. A customer service representative may need to contact you regarding the status of your repair, so include your name, address, phone number and e-mail address to speed the process.

IF THE UNIT IS OUTSIDE THE WARRANTY PERIOD, please include a check for \$7.50 to cover the cost of repair, handling and return postage. All out of warranty returns must be sent prepaid.

It is recommended that you contact SPECTRA first at 1-800-777-5331 or by e-mail at [info@spectraintl.com](mailto:info@spectraintl.com) for updated information on the unit requiring service. In some cases the model you have may be discontinued and SPECTRA reserves the right to offer alternative options for repair or replacement.

SPECTRA MERCHANDISING INTERNATIONAL, INC.  
4230 North Normandy Avenue,  
Chicago, IL60634, USA.  
1-800-777-5331

To register your product, visit the link below on the website to enter your information.

<http://www.spectraintl.com/wform.htm>