



paul frank[®]

™ & © 2011 Paul Frank Industries LLC. All Rights Reserved. Used Under Authorization.

CD Boombox with AM/FM Stereo Radio



Owner's Manual
PF224BK

CAUTION: Electrically Operated Product – Please use care when plugging into AC outlet.

WARNING: TO PREVENT FIRE OR SHOCK HAZARD, DO NOT EXPOSE THIS APPLIANCE TO RAIN OR MOISTURE.



The Caution Marking is located at the bottom of the apparatus.

IMPORTANT SAFETY INSTRUCTIONS

1. Read these instructions.
2. Keep these instructions.
3. Heed all warnings.
4. Follow all instructions
5. Do not use this apparatus near water.
6. Cleaning – Unplug this product from the wall outlet before cleaning. Do not use liquid cleaners or aerosol cleaners. Clean only with dry cloth.
7. Do not block any ventilation openings. Install in accordance with the manufacturer's instructions.
8. Do not place this product on an unstable cart, stand, tripod, bracket, or table. The product may fall, causing serious injury to a child or adult and serious damage to the product. Use only with a cart, stand, tripod, bracket, or table recommended by the manufacturer, or sold with the product. Any mounting of the product should follow the manufacturer's instructions, and should use a mounting accessory recommended by the manufacturer. A Product and Cart Combination Should Be Moved with Care – Quick stops, excessive force and uneven surfaces may cause the product and cart combination to overturn.
9. Do not install near any heat sources such as radiators, heat registers, stoves, or other apparatus (including amplifiers) that produce heat.
10. Do not defeat the safety purpose of the polarized or grounding-type plug. A polarized plug has two blades with one wider than the other. A grounding type plug has two blades and a third grounding prong. The wide blade or the third prong is provided for your safety. If the provided plug does not fit into your outlet, consult an electrician for replacement of the obsolete outlet.
11. Protect the power cord from being walked on or pinched particularly at plugs, convenience receptacles, and the point where they exit from the apparatus.
12. Only use attachments/accessories specified by the manufacturer.



13. Unplug this apparatus during lightening storms or when unused for long period of time.
14. Refer all servicing to qualified service personnel. Servicing is required when the apparatus has been damaged in any way, such as power-supply cord or plug is damaged, liquid has been spilled or objects have fallen into the apparatus, the apparatus has been exposed to rain or moisture, does not operate normally, or has been dropped.
15. This appliance shall not be exposed to dripping or splashing water and that no object filled with liquids such as vases shall be placed on the apparatus.
16. Do not overload wall outlet. Use only power source as indicated.
17. Use replacement part as specified by the manufacturer.
18. The product may be mounted to a wall only if recommended by the manufacturer.
19. Upon completion of any service or repairs to this product, ask the service technician to perform safety checks.
20. Excessive sound pressure from earphone and headphones can cause hearing loss.
21. Battery shall not be exposed to excessive heat such as sunshine, fire or the like.

COMPLIANCE WITH FCC REGULATIONS

This equipment has been tested and found to comply with the limits for a Class B Digital Device, pursuant to Part 15 of the FCC Rules. These limits are designed to provide reasonable protection against harmful interference in a residential installation. This equipment generates, uses and can radiate radio frequency energy and, if not installed and used in accordance with the instructions, may cause harmful interference to radio communications. However, there is no guarantee that interference will not occur in a particular installation. If this equipment does cause harmful interference to radio or television reception, which can be determined by turning the equipment off and on, the user is encouraged to try to correct the interference by one or more of the following measures:

- Reorient or relocate the receiving antenna.
- Increase the separation between the equipment and receiver.
- Connect the equipment into an outlet on a circuit different from that to which the receiver is connected.
- Consult the dealer or an experienced radio technician for help.

WARNING:

Changes or modifications to this unit not expressly approved by the party responsible for compliance could void the user's authority to operate the equipment.

CAUTION

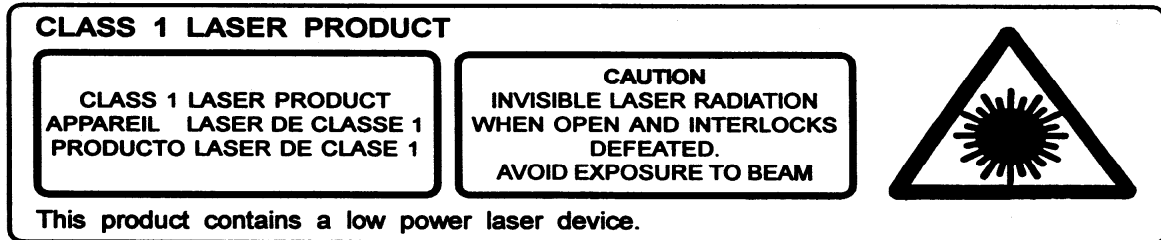

Follow the advice below for safe operations.

ON PROTECTION AGAINST LASER ENERGY EXPOSURE

- As the laser beam used in this compact disc player is harmful to the eyes, do not attempt to disassemble the casing.
- Stop operation immediately if any liquid or solid object should fall into the cabinet.
- Do not touch the lens or poke at it. If you do, you may damage the lens and the player may not operate properly.
- Do not put anything in the safety slot. If you do, the laser diode will be "ON" when the CD door is still open.
- If the unit is not to be used for a long period of time, make sure that all power sources are disconnected from the unit. Remove all batteries from the battery compartment, and unplug the AC cord from the wall outlet. Make it a practice to remove the AC cord by grasping the main body and not by pulling the cord.
- This unit employs a laser. The use of controls or adjustment or performance of procedures other than those specified here may result in exposure to hazardous radiation.

ON PLACEMENT

- Do not use the unit in places which are extremely hot, cold, dusty or humid.
- Place the unit on a flat and even surface.
- Do not restrict the air-flow of the unit by placing it in a place with poor ventilation, by covering it with a cloth or by placing it on a carpet.

ON CONDENSATION

- When left in a heated room where it is warm and damp, water droplets or condensation may form inside the unit.
- When there is condensation inside the unit, the unit may not function normally.
- Let it stand for 1 to 2 hours before turning the power on, or gradually heat the room up and dry the unit before use.

Should any trouble occur, remove the power source and refer servicing to qualified personnel.

LOCATION OF CONTROLS

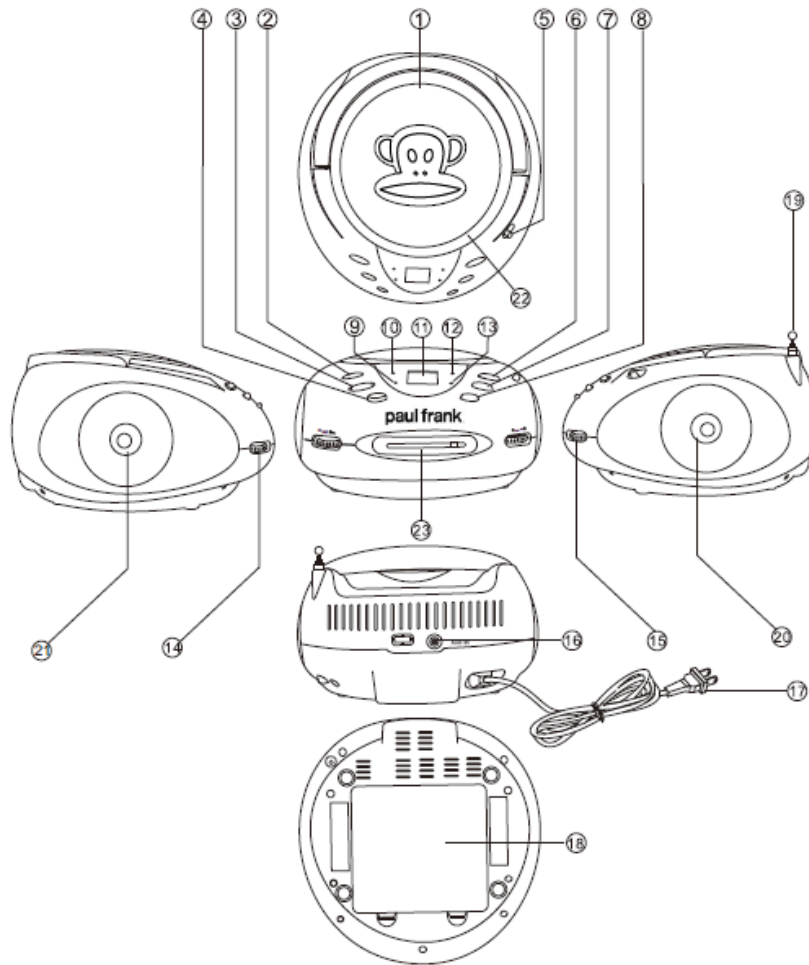

1. CD Door	13. Repeat Indicator
2. Play/Pause Button	14. Volume Control
3. Skip+/Search Forward ►► Button	15. Tuning Control
4. Skip-/Search Backward ◀◀ Button	16. AUX-IN Jack
5. Function Switch (OFF/CD/FM/AM)	17. AC INPUT Socket
6. Stop Button	18. Battery Compartment Door
7. Program (PROG) Button	19. Telescopic Antenna
8. Repeat (REP) Button	20. Speaker
9. FM Stereo Indicator	21. Speaker
10. Power Indicator	22. CD Door Open/Close
11. LED Display	23. Dial Scale
12. Play/Program Indicator	

POWER SOURCES

This unit operates on AC 120V~ 60Hz or 8 pieces of 1.5V “C” (UM-2) batteries (Not included). Do not attempt to operate the radio on any other power source. You could cause damage to the unit and void your warranty.

Please be sure the power outlet you plug this unit into is working and receives constant (unswitched) power.

A. BATTERY OPERATION

Note: For better performance and longer operating time, we recommend the use of alkaline-type batteries.

1. Remove the Battery Door.
2. Following the polarity diagram as shown in the battery compartment insert 8 x ‘LR14’ (‘C’) batteries then replace the battery door.

IMPORTANT: Be sure that the batteries are installed correctly. Wrong polarity may damage the unit.

3. Use only the size and type of batteries specified.
4. Do not mix old and new batteries.
5. Do not mix alkaline, standard (carbon-zinc) or rechargeable (nickel-cadmium) batteries.
6. If the unit is not to be used for an extended period of time, remove the batteries. Old or leaking batteries can cause damage to the unit and may void the warranty.
7. Do not try to recharge batteries not intended to be recharged; they can overheat and rupture. (Follow battery manufacturer’s directions).
8. Do not dispose of batteries in fire, batteries may leak or explode.

BATTERY REPLACEMENT

When the output sound of this unit becomes distorted or the CD player operation appears unstable, the batteries are weak. You need to replace all the exhausted batteries at the same time as soon as possible to avoid battery leakage.

B. AC OPERATION

When the AC power cord (included) is connected to the AC INPUT Socket at the back of the unit and the other end to a wall outlet with AC 120V ~ 60Hz power supply, the unit will disconnect the batteries automatically, and operate from AC power instead.

IMPORTANT:

This unit has a polarized AC plug with one wide blade and one narrow blade. This plug will only fit into a matching polarized AC outlet. This is a safety feature to reduce the possibility of electric shock. If this plug will not fit in your AC outlet, you probably have an outdated non-polarized outlet. You should have your out-dated outlet changed by a qualified, licensed electrician. Do not file the wide blade on the plug, or use an adaptor to make the plug fit onto your outlet. This defeats the safety feature and could expose you to electric shock.

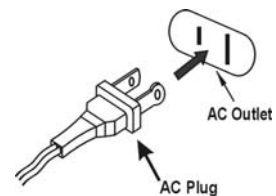

RADIO OPERATION

1. Slide the FUNCTION SWITCH to "FM" or "AM" as desired. The POWER Indicator will light.
2. Rotate the TUNING CONTROL to your desired radio station according to the DIAL SCALE on the unit.
3. Rotate the VOLUME CONTROL to adjust to the desired output level.
4. To turn off the radio, slide the FUNCTION SWITCH to "OFF". The POWER Indicator will go off.

TIPS FOR BEST RECEPTION

AM – The AM antenna is located inside the cabinet of the unit. If AM reception is weak, change the position of unit until the internal antenna picks up the strongest signal.

FM – If a stereo broadcast program is being received, the FM STEREO INDICATOR will light. During FM or FM Stereo reception, always keep the FM TELESCOPIC ANTENNA fully extended for best performance. However, if FM reception is weak, try repositioning the unit near an open window until you get the best reception.

CD OPERATION

NOTE: THIS UNIT NOT ONLY PLAYS COMMERCIAL COMPACT DISCS BUT ALSO SELF-COMPILED CD-RW DISCS.

- Because of non-standardized format definition/production of CD-R/RW, playback quality & performance is not guaranteed.
- Manufacturer is not responsible for the playability of CD-R/RW due to recording conditions such as PC performance, writing software, media properties etc.
- Do not attach a label or seal to either side of the CD-R/RW disc. It may cause a malfunction.

PLAY MODE

1. Slide the FUNCTION SWITCH to the "CD" position. The POWER INDICATOR will light.
2. Open the CD DOOR, load a CD with the label side facing upward and then close the CD door.
3. A few seconds later the total number of tracks on the CD will appear on the LED DISPLAY.
4. Press the PLAY/PAUSE BUTTON to start playing the CD from the first track. The PLAY/PROG INDICATOR will light steadily.
5. While playing, press the PLAY/PAUSE BUTTON once to pause, the LED DISPLAY will flash. Press PLAY/PAUSE BUTTON again to resume playing.
6. Adjust the VOLUME CONTROL to the desired volume level.
7. Press STOP BUTTON to stop playing.
8. To turn off the CD player, slide the FUNCTION SWITCH to "OFF". The POWER INDICATOR will go off.

NOTE: If skipping occurs during CD play, try turning the volume down.
Do not open the CD DOOR when a CD is playing.

REPEAT MODE

Repeat 1

When the REPEAT BUTTON is pressed once, the REPEAT INDICATOR will light and blink continuously. The current track will be repeated until it is interrupted.

Repeat All

When the REPEAT BUTTON is pressed twice, the REPEAT INDICATOR will light steadily. The whole disc will be played continuously.

To Cancel the Repeat Function: Press the REPEAT BUTTON until the repeat indicator goes off.

SKIP AND SEARCH MODE

1. During Play or Pause mode, tap the SKIP + or SKIP - BUTTON to go to the next track or go back to the beginning of the current track.
2. During Play mode or Pause mode, press and hold the SKIP + or SKIP - BUTTON to search within the current track with audible high speed playback.

PROGRAM PLAY MODE

This function allows music tracks to be played in a programmed sequence.

NOTE: Program can only be set in STOP mode.

1. Press the PROGRAM BUTTON once. Both Program Number "01" and the PROGRAM INDICATOR will flash.
2. Press the SKIP + or SKIP - BUTTON to select the track to be programmed.
3. Press the PROGRAM BUTTON again to store the selection. The Program Number will advance to "02" and flash to prompt for the next input.
4. You may repeat steps #2 to #3 to program up to 20 tracks. As soon as you have entered the 20th track, the LED DISPLAY will automatically show the programmed tracks one by one in their correct sequence starting from the first. At the end of program review, Program Number "01" and the PROGRAM INDICATOR will both flash.
5. Press the PLAY BUTTON to complete and start program play. Press the STOP BUTTON to stop.
6. To review/edit the programmed tracks during play, press the STOP BUTTON and then the PROGRAM BUTTON, the LED DISPLAY will automatically show the programmed tracks one by one in their correct sequence starting from the first. At the end of program review, Program Number "01" and the PROGRAM INDICATOR will both flash. If you do not want to change any track in the program, press PLAY BUTTON.
7. To edit a programmed track, first press the PROGRAM BUTTON until you reach the program number whose track you want to change then press the SKIP+ or SKIP-BUTTON to select a new track and press PROGRAM BUTTON again to confirm.
8. To cancel program play, press the STOP BUTTON twice while reviewing programmed tracks or open the CD DOOR in STOP mode.
9. To turn off the CD player, slide the FUNCTION Switch to "OFF". The POWER Indicator will go off.

AUX IN OPERATION

This CD Player includes an AUX IN JACK so you can enjoy your iPod, MP3 player or other audio device.

1. Connect the headphone jack of your external device and the AUX IN jack located on the back of this CD player. (The connection cable is not included.)
2. Turn on the CD player and it will enter the AUX function mode once the AUX IN jack is plugged.
3. Start to play your iPod, MP3 player or other audio device.
4. Slowly adjust both the volume controls on your CD player and the external device.
5. Turn off your iPod, MP3 player etc. when you finished listening. Turn the CD player off and unplug the AUX IN jack.

Remark: Once the AUX IN jack is plugged, the CD player will enter the AUX mode automatically no matter the FUNCTION Switch is in CD, FM or AM mode. Remember to disconnect the connection cable from the CD player after use in order to be able to listen to CD music, FM or AM broadcasts again.

CARE AND MAINTENANCE

1. Children should be supervised when using this appliance.
2. Clean your unit with a damp (never wet) cloth. Solvent or detergent should never be used.
3. Avoid leaving your unit in direct sunlight or in hot, humid or dusty places.
4. Keep your unit away from heating appliances and sources of electrical noise such as fluorescent lamps or motors.
5. If drop-outs or interruptions occur in the music during CD play, or if the CD fails to play at all, its bottom surface may require cleaning. Before playing, wipe the disc from the center outwards with a good soft cleaning cloth.



PROTECT YOUR FURNITURE!!

This system is equipped with non-skid rubber 'feet' to prevent the product from moving when you operate the controls. These 'feet' are made from non-migrating rubber material specially formulated to avoid leaving any marks or stains on your furniture. However certain types of oil based furniture polishes, wood preservatives, or cleaning sprays may cause the rubber 'feet' to soften, and leave marks or a rubber residue on the furniture.

To prevent any damage to your furniture we strongly recommend that you purchase small self-adhesive felt pads, available at hardware stores and home improvement centers everywhere, and apply these pads to the bottom of the rubber 'feet' before you place the product on fine wooden furniture.

TROUBLESHOOTING GUIDE

If you experience difficulties in the use of this music system please check the following or call 1-800-777-5331 for Customer Service and Support.

Symptom	Possible Cause	Solution
Noise or sound distorted on AM or FM broadcast	<ul style="list-style-type: none"> - Station not tuned properly for AM or FM. - FM: FM telescopic antenna is not extended. - AM: The bar antenna is not positioned correctly 	<ul style="list-style-type: none"> - Retune the AM or FM broadcast station. - FM: Extend FM telescopic antenna. - AM: Reposition the unit until the best reception is obtained.
AM or FM no sound	<ul style="list-style-type: none"> - Unit not in "AM" or "FM" function mode. - Volume set at minimum 	<ul style="list-style-type: none"> - Slide Function Switch to "AM" or "FM" position. - Increase Volume.
CD player will not play	<ul style="list-style-type: none"> - Unit not in CD function mode. - CD is not loaded properly. - If the CD is self-compiled, the media used may not be compatible with the player. - Exhausted battery 	<ul style="list-style-type: none"> - Select CD function mode. - Load CD with label side up. - Use better quality blank media and retest. - Replace all old batteries.
CD skips while playing	<ul style="list-style-type: none"> - Disc is dirty or scratched. 	<ul style="list-style-type: none"> - Wipe CD with clean cloth or use another disc.
Intermittent sound from CD player	<ul style="list-style-type: none"> - Dirty or defective disc - Dirty pick up lens - Player is subject to excessive shock or vibration 	<ul style="list-style-type: none"> - Clean or replace the defective disc. - Use a CD lens cleaning disc to clean the lens. - Relocate the player away from shock or vibration.
Sound appears distorted at high volume setting	<ul style="list-style-type: none"> - Volume control is set to maximum. - Batteries become low 	<ul style="list-style-type: none"> - Adjust Volume Control to a lower comfortable level. - Replace all the old batteries with new ones.

90 DAY LIMITED WARRANTY AND SERVICE

VALID IN THE U.S.A ONLY

SPECTRA MERCHANDISING INTERNATIONAL, INC. warrants this unit to be free from defective materials or factory workmanship for a period of 90 days from the date of original customer purchase and provided the product is utilized within the U.S.A. This warranty is not assignable or transferable. Our obligation under this warranty is the repair or replacement of the defective unit or any part thereof, except batteries, when it is returned to the SPECTRA Service Department, accompanied by proof of the date of original consumer purchase, such as a duplicated copy of a sales receipt.

You must pay all shipping charges required to ship the product to SPECTRA for warranty service. If the product is repaired or replaced under warranty, the return charges will be at SPECTRA's expense. There are no other express warranties other than those stated herein.

This warranty is valid only in accordance with the conditions set forth below:

1. The warranty applies to the SPECTRA product only while:
 - a. It remains in the possession of the original purchaser and proof of purchase is demonstrated
 - b. It has not been subjected to accident, misuse, abuse, improper service, usage outside the descriptions and warnings covered within the owner's manual or non-SPECTRA approved modifications
 - c. Claims are made within the warranty period
2. This warranty does not cover damage or equipment failure caused by electrical wiring not in compliance with electrical codes or SPECTRA owner's manual specifications, or failure to provide reasonable care and necessary maintenance as outlined in the owner's manual.
3. Warranty of all SPECTRA products applies to residential use only and is void when products are used in a nonresidential environment or installed outside the United States.

This warranty gives you specific legal rights, and you may also have other rights which vary from state to state. TO OBTAIN SERVICE please remove all batteries (if any) and pack the unit carefully and send it prepaid by insured parcel post or UPS to SPECTRA at the address shown below. IF THE UNIT IS RETURNED WITHIN THE WARRANTY PERIOD shown above, please include a proof of purchase (dated cash register receipt) so that we may establish your eligibility for warranty service and repair of the unit without cost. Also include a note with a description explaining how the unit is defective. A customer service representative may need to contact you regarding the status of your repair, so include your name, address, phone number and e-mail address to speed the process.

IF THE UNIT IS OUTSIDE THE WARRANTY PERIOD, please include a check for **\$20.00** to cover the cost of repair, handling and return postage. All out of warranty returns must be sent prepaid.

It is recommended that you contact SPECTRA first at 1-800-777-5331 or by e-mail at info@spectrainl.com for updated information on the unit requiring service. In some cases the model you have may be discontinued and SPECTRA reserves the right to offer alternative options for repair or replacement.

SPECTRA MERCHANDISING INTERNATIONAL, INC.
4230 North Normandy Avenue,
Chicago, IL60634, USA.
1-800-777-5331

To register your product, visit the link below on the website to enter your information.
<http://www.spectrainl.com/wform.htm>

Printed in China